

---

# ***COLLATOR SYSTEM***

## **DC-10000S**

---

### **INSTRUCTION MANUAL**

---

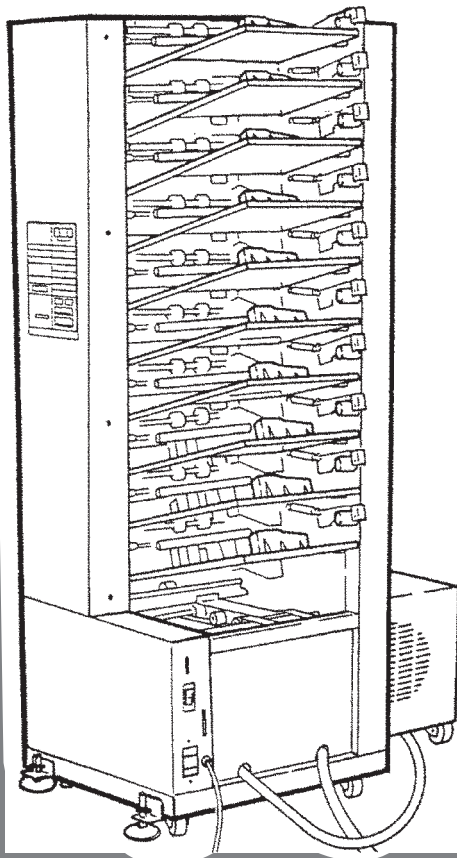

**Duplo**



## DECLARATION OF CONFORMITY

Duplo Corporation, located at 7-6, Izumi Honcho 1-chome, Komae-shi, Tokyo 201, Japan, declares that the following product,

Name of product : COLLATING MACHINE

Type No. : DC-10000S /DC-8000S 2

Complies with the provisions defined by the regulations listed below.

Regulation : Machinery Directive 89/392/EEC and Low Voltage Directive 73/23/EEC under the application of EN60950:1992 / A1:1993/ A2:1993.

Electromagnetic Compatibility Directive 89/336/EEC under the application of EN55022:1987, EN50082-1:1992.

Note : The testing of Electromagnetic Compatibility Directive is executed under the configuration.

## ÜBEREINSTIMMUNGSERKLÄRUNG

Die Duplo Corporation mit Sitz in 7-6, Izumi Honcho 1-chome, Komae-shi, Tokyo 201, Japan, versichert, daß das folgende produkt,

Bezeichnung des Produkts :ZUSAMMENGETRAGEN

Typen-Nr. : DC-10000S /DC-8000S 2

Entspricht den Bestimmungen, wie sie durch die unten aufgeführten Vorschriften definiert sind.

Vorschriften : Maschinenrichtlinie 89/392/EEC und EWG-Niederspannungsrichtlinie 73/23/EEC unter Anwendung der EN60950:1992/ A1:1993/ A2:1993.

Vorschriften für elektromagnetische Störungsfreiheit 89/336/EEC unter Anwendung der EN55022:1987, EN50082-1:1992.

Zur besonderen Beachtung : Die Messungen der elektromagnetischen Abstrahlungen sind unter folgenden konfigurationen.

## DECLARATION DE CONFORMITE

Duplo Corporation, située à 7-6, Izumi Honcho 1-chome, Komae-shi, Tokyo 201, Japon, déclare que le produit suivant;

Nom du produit : ASSEMBLEUSE

No, de type : DC-10000S /DC-8000S 2

est conforme aux dispositions définies par les réglementations suivantes;

Réglementations : Directive sur la machinerie 89/392/EEC et Directive sur la basse tension 73/23/EEC en application de EN60950:1992/ A1:1993/ A2:1993.

Directive de compatibilité électromagnétique 89/336/EEC application de EN55022:1987, EN50082-1:1992.

A noter : Les tests des directives de Comptabilité Electromagnétique ont été exécutés pour la configuration.

Test configuration /Prüfung-Konfiguration /Essayer la configuration :

1. DC-10000S (or DC-8000S 2) + DC-8000S P + DC-8000S RD + LU-HM + DC-48SH 3 + DC-48F 3 + DC-48T 3 (or DC-48ST 2).
2. DC-10000S (or DC-8000S 2) + DC-8000S P + DC-8000S RD + DC-12JR.
3. DC-10000S (or DC-8000S 2) x 2 + DC-8000S P x 2 + DC-8000S D + LU-HM + DBM-200 + DC-48TW.
4. DC-10000S (or DC-8000S 2) x 2 + DC-8000S P x 2 + DC-8000S D + LU-HM + DBM-200 + DC-48ST 2.

# TABLE OF CONTENTS

---

1. Precautions .....	1	11. Operation Procedures .....	42
Vorsichtsmaßnahmen .....	3	12. Feeding Small Paper	
Précautions .....	5	(Only When DBM-200 is Connected) .....	52
2. Names and Functions of the Components .....	7	13. Using the LU-HM .....	53
3. Names and Functions of the Control Panel		13-1. Manual Mode 1 .....	53
Components .....	9	13-2. Manual Mode 2 .....	55
4. Functions of the DIP Switches and		14. Supplementary Operation to be Performed	
Their Use .....	14	When the Machine is in Operation .....	56
4-1. Tower Names and Setting the DIP		14-1. Checking the Accumulated Total	
Switches .....	14	Number of Sets Collated .....	56
4-2. Connecting the Towers and Setting		14-2. Checking the Number of Sets Rejected ...	56
the DIP Switches .....	15	14-3. Decreasing Processing Speed .....	56
4-3. Selecting the Functions .....	16	14-4. Changing the Overlap Volume in	
5. Selecting the Paper Ejection Direction .....	19	Conveying Paper .....	57
6. Setting the Program Mode and		14-5. Returning to the Previous Mode by	
the Block Mode .....	20	Turning Power ON Again after Power	
7. Functions of the Program Modes and		is Cut OFF during Operation .....	57
Their Use .....	24	14-6. Operating the Stitcher Manually .....	58
7-1. Auto Mode .....	24	15. Clearing Paper Jams .....	59
7-2. 5-Bin Mode .....	24	15-1. Jamming in the Feeding Section .....	59
7-3. 10-Bin Mode .....	25	15-2. Jamming in the Vertical Conveyance	
7-4. Alt All Mode .....	25	Section .....	60
7-5. Alt Cover Mode .....	26	15-3. Jamming in the Lifting Unit Section .....	60
8. Functions of the Block Modes and Examples		15-4. Jamming in the Conveyance Bridge	
of Their Use .....	27	Section .....	61
8-1. Setting the Block Mode .....	27	15-5. Jamming in the Right Ejection Unit	
8-2. Example of Using the 1/2 Mode .....	27	Section .....	61
8-3. Example of Using the 1/4 Mode .....	29	16. Replacing the Suction Pad .....	62
8-4. Example of Using the 1/3 Mode .....	31	17. Monitor Lamp Displays and Their	
9. Using the Cover Insert Mode .....	33	Countermeasures .....	63
9-1. Setting the Cover Insert Mode .....	33	17-1. When the door Lamp Lights Up .....	63
9-2. Setting When to Insert Cover .....	34	17-2. When the empty Lamp Lights Up .....	64
9-3. Setting the Number of Volumes to be		17-3. When the feed error Lamp Lights Up ....	67
Collated .....	35	17-4. When the delivery Lamp Lights Up .....	69
10. Loading the Paper .....	36	18. Troubleshooting Guide .....	70
10-1. Precautions to be Taken in Loading		19. Everyday Cleaning .....	72
Paper .....	36	20. Checking and Maintenance of the Dry Pump .....	73
10-2. Loading Paper for the General Collation		21. Specifications .....	74
Operation .....	37		
10-3. Loading Paper for the Collation			
Operation with Cover Inserted .....	38		
10-4. Precautions to be Taken in Loading			
Thick Paper .....	40		
10-5. Precautions to be Taken in the Right			
Ejection Mode .....	41		

# 1. PRECAUTIONS

---

Keep the following in mind for safe operation.

- Do not forget to remove metallic objects left in the machine as they may cause malfunction or injury otherwise.
- Do not touch the rotating section and do not put anything into the machine while the machine is working, as this may result in injury.
- Do not stand on the pump case to prevent damage or injury.
- Do not remove the panel, cover, or any other component of the machine, and do not modify any. Malfunction or mechanical trouble may be caused by doing so.
- Put the plug into the closest and most accessible 230 to 240 V wall socket.
- Leave it disconnected to the outlet when it is not used.

## 1. PRECAUTIONS

---

- Note the following.

① Do not unplug the power cord by pulling the cord.

- Grasp the plug section to unplug the power cord.

② Check whether the power plug overheats.

Contact the service agent to check it.

③ Check whether there are cracks or scratches on the power cord.

If there are, ask the service agent to replace the cord.

④ Check whether the power cord is plugged into the outlet.

Plug in the power cord firmly.

⑤ Check whether the power voltage drops.

If the machine stops operating normally suddenly when another copy machine or other equipments are installed, ask a service agent to check it.

# 1. VORSICHTSMAßNAHMEN

---

Im Sinne eines sicheren Betriebs beachten Sie bitte die folgenden Punkte.

- Vergessen Sie nicht Metallgegenstände oder andere Fremdkörper aus der Maschine zu entfernen, da diese zu Störungen oder ansonsten zu Verletzungen führen können.
- Nicht den sich drehenden Abschnitt anfassen oder irgendwelche Gegenstände in die Maschine einbringen, während sie in Betrieb ist, da dies zu Verletzungen führen kann.
- Nicht auf dem Pumpengehäuse stehen, um Beschädigungen oder Verletzungen zu vermeiden.
- Nicht Platten, Abdeckungen oder andere Teile der Maschine entfernen oder modifizieren. Dies könnten zu mechanischen Störungen führen.
- Schließen Sie den Netzstecker an eine leicht zugängliche Steckdose (230/240 V) an.
- Ziehen Sie den Netzstecker, wenn die Maschine voraussichtlich längere Zeit nicht gebraucht wird.

• Beachten Sie das Folgende.

- ① Das Netzkabel nicht durch Ziehen am Kabel aus der Steckdose ziehen.

- Ziehen Sie das Netzkabel aus der Steckdose, indem Sie es am Stecker halten.

- ② Prüfen Sie, ob sich der Stecker überhitzt.

Benachrichtigen Sie den Kundendienstingenieur, um den Stecker inspizieren zu lassen.

- ③ Prüfen Sie, ob das Kabel Risse oder Schrammen hat.

Wenn ja, wenden Sie sich mit der Bitte um Ersatz des Kabels an den Kundendienst.

- ④ Prüfen Sie, ob das Netzkabel an eine Steckdose angeschlossen ist.

Den Stecker fest in die Steckdose stecken.

- ⑤ Prüfen Sie, ob die Spannung der Stromversorgung abfällt.

Wenn der normale Betrieb der Maschine plötzlich aussetzt wenn ein Kopierer oder ein anderes Gerät installiert wird, bitten Sie den Kundendienst um eine Inspektion.

# 1. PRÉCAUTIONS

---

Observer les règles suivantes pour assurer un fonctionnement sûr.

- Toujours retirer les pièces métalliques ou autres matières étrangères qui auraient pu tomber dans la machine avant de l'utiliser, sinon ils pourraient provoquer un mauvais fonctionnement ou des blessures.
- Ne pas toucher les pièces rotatives de la machine, ni insérer quelque chose à l'intérieur pendant le fonctionnement, cela pourrait provoquer des blessures.
- Ne pas monter sur le cache de protection de la pompe, c'est très dangereux.
- Ne pas retirer de panneau, couvercle ou autre composant de la machine, et ne pas la trafiquer. Cela pourrait se traduire par un mauvais fonctionnement ou un problème mécanique.
- Brancher le cordon d'alimentation à la prise murale de 230/240 V la plus proche et la plus accessible.
- Débrancher le cordon de la prise murale lorsque la machine n'est pas utilisée.



## 1. PRÉCAUTIONS

---

- Noter les points suivants:

- ① Ne pas débrancher le cordon d'alimentation en tirant sur le cordon.

- Saisir la fiche pour le débrancher.

- ② Vérifier si la fiche d'alimentation n'est pas anormalement chaude.

Demander à un agent de service de la vérifier.

- ③ Vérifier si le cordon d'alimentation n'est pas fissuré ou rayé.

Si oui, demander à un agent de service de la remplacer.

- ④ Vérifier si le cordon d'alimentation est bien inséré dans la prise.

L'insérer fermement.

- ⑤ La tension d'alimentation baisse-t-elle parfois?

Si la machine s'arrête brusquement de fonctionner normalement quand un autre copieur ou un autre appareil est installé, demander à un agent de service de faire un contrôle.

## 2. NAMES AND FUNCTIONS OF THE COMPONENTS

---

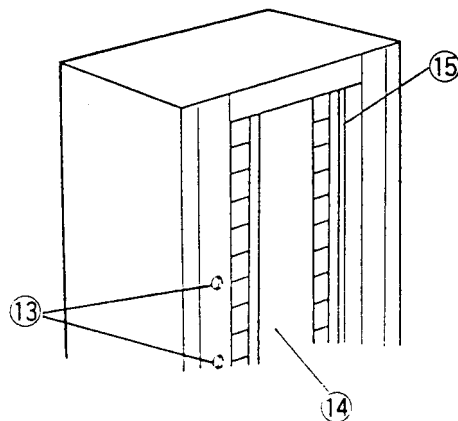
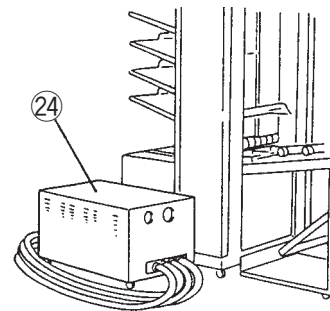
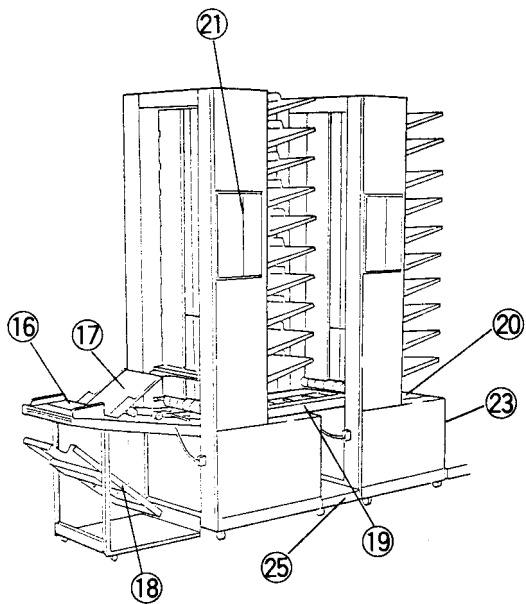
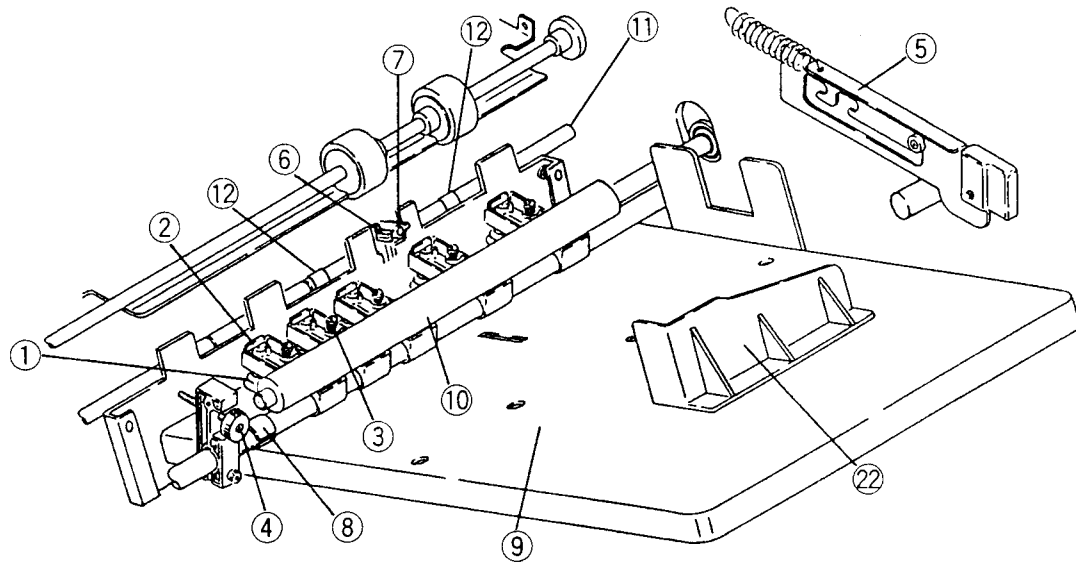

## 2. NAMES AND FUNCTIONS OF THE COMPONENTS

No.	Item	Function
1	Suction cup	Sucks the paper on the paper feed bin.
2	Valve	Sucking or not is selected by switching this valve.
3	Paper guide	4 settings are possible. Select a suitable setting according to paper conditions.
4	Knob for adjusting suction cup height	Adjusts suction cup position.
5	Bin pressure switch lever	This lever is used to select bin pressure according to paper conditions.
6	Brush	Separates the paper sucked to the suction cup so that the paper is fed one by one.
7	Separator B	Feeds air between the papers when they are conveyed.
8	Shutter	Adjusts the suction force with 4 settings.
9	Paper feed bin	The bin where the paper is placed.
10	Stopper	Keeps the paper on the paper feed bin positioned in alignment.
11	Separator pipe	Feeds air between the paper during suction.
12	Separator shutter	Adjusts the air feeding position.
13	Conveyance pressure switching hole	Feeds thick or heavy paper.
14	Vertical conveyance board	Conveys fed paper.
15	Sub-guide	This presses down the end of the paper during conveyance to prevent the paper from becoming inflated.
16	Lifting unit	Conveys collated paper to the downstream processing machine.
17	HM section	Enables sets of up to ten sheets of paper to be inserted manually.
18	Reject tray	Double-fed or mis-collated set is ejected to this tray.
19	Conveyance bridge	Conveys fed paper.
20	Right ejection unit	Conveys collated paper.
21	Panel	Refer to "3. NAMES AND FUNCTIONS OF THE CONTROL PANEL COMPONENTS".
22	Corner guide	This guides the corner of the paper to keep the paper in position.
23	Power switch	The machine is in the standby state with the power switched ON.
24	Dry pump	Picks up the paper or sends an air blast to the paper.
25	Connecting board	Used for connecting and securing towers.

# 3. NAMES AND FUNCTIONS OF THE CONTROL PANEL COMPONENTS

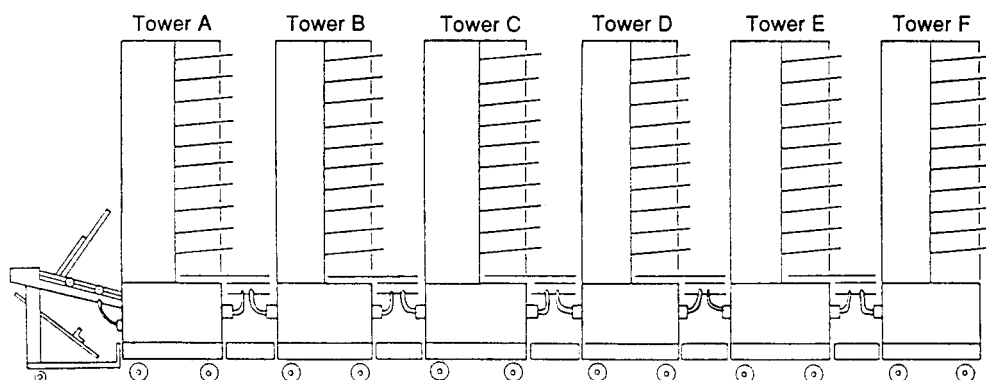
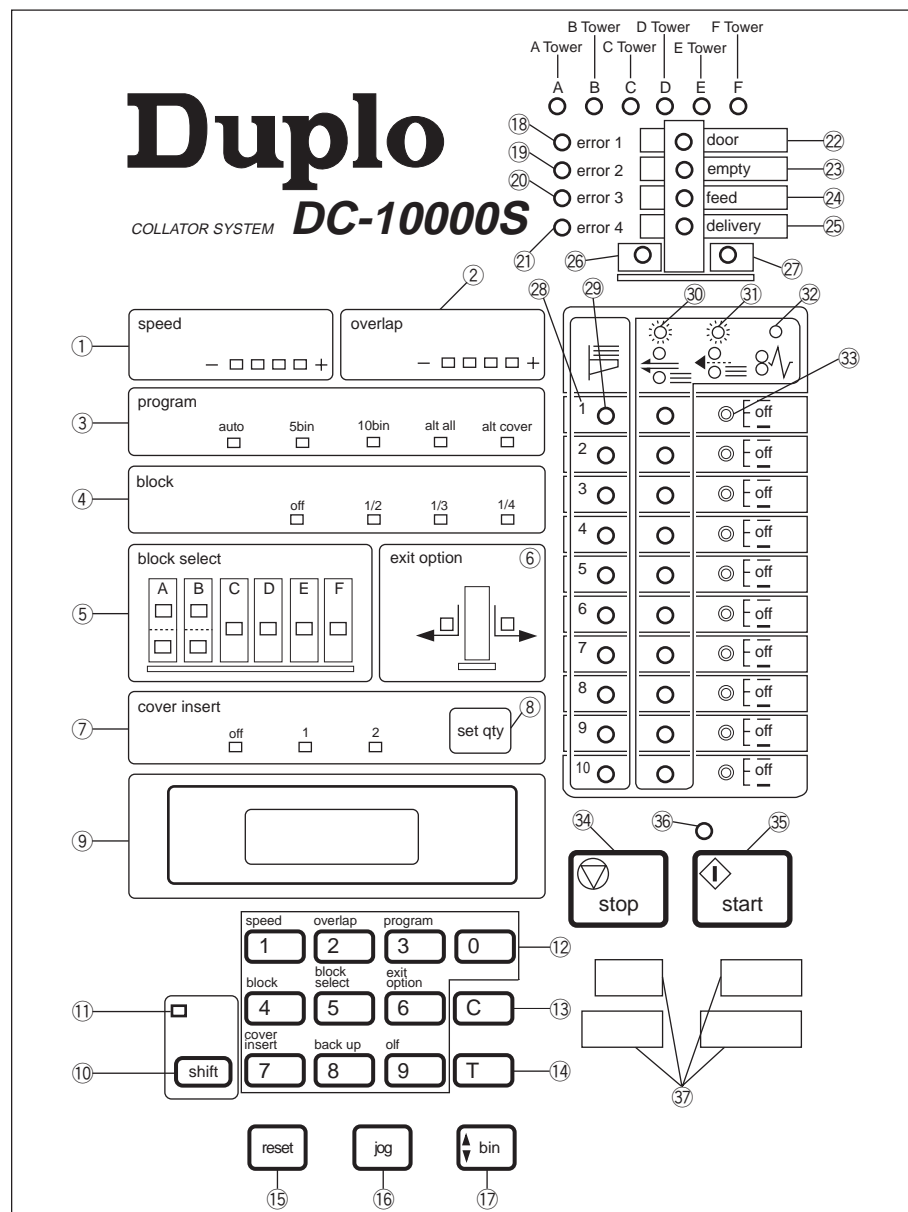

\* The connected collators are called as follows:

As shown in the above drawing, the first collator is called Tower A, and Tower B, Tower C, Tower D, Tower E and Tower F in order.

### 3. NAMES AND FUNCTIONS OF THE CONTROL PANEL COMPONENTS

No.	Name	Function	
1	Speed lamp	The collation processing speed is indicated by 4 settings. The lamp display moves in the direction of (–) every time the “1” key on the keypad is pressed with the shift key held down. The maximum (+) is displayed when the power is turned on.	
2	Overlap lamp	The overlap of paper feed timing for the paper on the paper feed bin is indicated by 4 settings. The lamp display moves in the direction of (+) every time the “2” key on the keypad is pressed with the shift key held down. The minimum (–) is displayed when the power is turned on.	
3	Program	Auto lamp	This lights up when the auto mode is selected. The paper in all the paper feed bins is fed in this mode. This mode is displayed when the power is turned on in the normal collation mode.
		5-bin lamp	This lights up when the 5-bin mode is selected. Collation is processed in order for the 5 bins divided from all the bins in this mode. This is suitable for printed matter of 5 pages or less.
		10-bin lamp	This lights up when the 10-bin mode is selected. Collation is processed in order for the 10 bins divided from all the bins in this mode. This is suitable for printed matter of 10 pages or less.
		Alt all lamp	This lights up when the alternate all mode is selected. This mode is used to place the same page on the upper and lower (two) bins: the first and second bins, the third and fourth bins, the fifth and sixth bins, the seventh and eighth bins and the ninth and tenth bins. The paper on the upper or lower bin is fed. Feeding starts from the upper bin and is automatically switched to the lower bin when paper runs out on the upper bin.
		Alt cover lamp	This lights up when the alternate cover mode is selected. This mode is used to the cover paper. The cover paper is placed on the first and second bins and it is fed from either bin. Feeding starts from the upper bin and is automatically switched to the lower bin when paper runs out on the upper bin.
	Setting the program mode	Every time the “3” key on the keypad is pressed with the shift key held down, the display shows the 5-bin, 10-bin, alt all, alt cover, and auto and then repeats them.  <b>NOTE</b> : Mode selection condition depends on the number of connected towers. For further details, refer to “6. SETTING THE PROGRAM MODE AND THE BLOCK MODE”.	

3. NAMES AND FUNCTIONS OF THE CONTROL PANEL COMPONENTS

No.	Item		Function
4	Block	Off lamp	This lights up when the block mode is not selected. This is set when the power is turned on in the normal collation mode.
		1/2 lamp	This lights up when the 1/2 block mode is selected. All the bins on the connected towers are divided into 2 blocks and collation is performed by block.
		1/3 lamp	This lights up when the 1/3 block mode is selected. All the bins on the connected towers are divided into 3 blocks and collation is performed by block.
		1/4 lamp	This lights up when the 1/4 block mode is selected. All the bins on the connected towers are divided into 4 blocks and collation is performed by block.
	Setting the block mode		Every time the “4” key on the keypad is pressed with the shift key held down, the display shows 1/2, 1/3, 1/4, off, then repeats them.  <b>NOTE</b> : Mode selection conditions depend on the number of connected towers. For further details, refer to “6. SETTING THE BLOCK MODE AND THE PROGRAM MODE”.
5	Block select lamp		The lamp of the collation processing block lights up. Press the “5” key on the keypad with the shift key held down to select a block.
6	Exit option lamp		The collated set is ejected in the direction of an arrow on the lit lamp. Press the “6” key on the keypad with the shift key held down to select paper ejection direction.
7	Cover insert	Off lamp	This lights up when the cover insert mode has not been selected.
		1 lamp	This lights up when the cover insert mode 1 is selected. In this mode a sheet of cover can be inserted. For further details, refer to “9. USING THE COVER INSERT MODE” .
		2 lamp	This lights up when cover insert mode 2 is selected. In this mode 2 sheets of cover can be inserted. For further details, refer to “9. USING THE COVER INSERT MODE” .
	Selecting the cover insert mode		Every time the “7” key on the keypad is pressed with the shift key held down, the display shows 1, 2, off, then repeats them.
8	Set qty key		Input the number of sets on the keypad with this key held down to determine when to insert a cover sheet. The input figure is displayed on the display window. The maximum number to be input is 999 (sets).

### 3. NAMES AND FUNCTIONS OF THE CONTROL PANEL COMPONENTS

No.	Item	Function
9	The display window for the number of sets	The number input on the keypad is displayed. The number on the window is subtracted as collation is processed. The remaining number to be collated is displayed on the window. The number of sets with cover inserted is displayed while the set qty key is held down.
10	Shift key	This is used with the keypad to set the mode or switch operation.
11	Shift lamp	This lights up when the shift key is pressed.
12	Keypad (0 to 9)	This is used to input the number of sets to be collated. It also has various functions stated on the upper section of each key when it is used together with the shift key. The number of sets after which a cover is inserted is also input when it is used with the set qty key. When connecting, only the key for tower A is valid.
13	C key	Press this key to return the display number to "0". Hold this key down for about one second to cancel or change the display number, the electric buzzer sounds and the display returns to "0". When connecting, only the key for tower A is valid.
14	T key	The accumulated total number of sets collated after the power is turned on is confirmed with the T key pressed.
15	Reset key	Press this key to commence collation operation. Press this key when "0" is displayed on the display window for the number of sets. The paper is fed to memorize the paper thickness for each paper feed bin. Do not forget to operate this before commencing collation when the paper is replaced on the bin during operation.
16	Jog key	The paper conveyance motor rotates while this key is pressed. The jammed paper is ejected by pressing this key when a paper jam occurs in the machine.
17	Bin key	All the feed bins move up and down every time this key is pressed. The paper can be placed when the bin is moved down.
18	Error 1 lamp	<When the paper is ejected to the left> This lights up when only the set including a mis-fed paper sheet is conveyed into the reject tray. <When the paper is ejected to the right> Check the set ejected last to the downstream processing machine as it is mis-collated.
19	Error 2 lamp	<When the paper is ejected to the left> This lights up when the machine stops operation after one set including a mis-fed paper sheet has been conveyed into the downstream processing machine and after the next set has been conveyed to the reject tray. <When the paper is ejected to the right> Check the last two sets ejected to the downstream processing machine as they are mis-collated.

### 3. NAMES AND FUNCTIONS OF THE CONTROL PANEL COMPONENTS

No.	Item	Function
20	Error 3 lamp	Not used
21	Error 4 lamp	Not used
22	Door lamp	The door lamp on the relevant tower lights up when the vertical conveyance board, conveyance bridge or lifting unit is open. The machine does not work while this is lit.
23	Empty lamp	The empty lamp on the relevant tower lights up when paper runs out on the paper feed bin, and the machine stops operation.
24	Feed lamp	The feed lamp on the relevant tower lights up when a double-feed, mis-feed or paper jam is detected, and the machine stops operation.
25	Paper jam lamp	The paper jam lamp on the relevant tower lights up when the paper jams on the conveyor, and the machine stops.
26	Left connected unit error lamp	The left connected unit error lamp lights up when a problem arises in the downstream processing machine connected on the left, and the machine stops.
27	Right connected unit error lamp	When an error occurs in the connected unit on the right, this lamp lights up and the machine stops operation except the jogger device (DC-12JR).
28	Numbers	These are bin numbers.
29	Paper lamp	This lights up when paper is placed on the paper feed bin. The paper lamp on the relevant bin goes on and off when the paper runs out, and the machine stops.
30	Double-feed lamp	The double-feed lamp (red) on the relevant bin blinks when a double-feed occurs, and the machine stops.
31	Mis-feed lamp	The mis-feed lamp (yellow) on the relevant bin blinks when a mis-feed occurs, and the machine stops.
32	Jam lamp	The jam lamp (red) on the relevant bin lights up when a paper jam occurs, and the machine stops.
33	Double-feed sensitivity switch	This switch adjusts the sensitivity of the double sheet detector according to paper weight and type.
34	Stop key	Press this key to stop the machine.
35	Start key	Press this key to commence operation.
36	Start lamp	The start lamp lights up when the machine starts operation.
37	DIP switches	Refer to "4. FUNCTIONS OF THE DIP SWITCHES AND THEIR USE".



# 4. FUNCTIONS OF THE DIP SWITCHES AND THEIR USE

DIP switches are attached to the control panel.  
 DIP switches are set at the factory as follows:

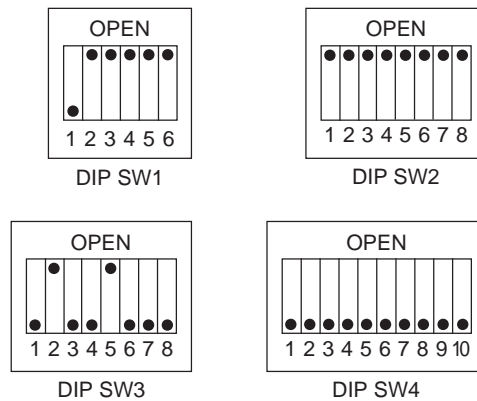

- As shown in the figure, four DIP switches are built in: DIP SW1, DIP SW2, DIP SW3 and DIP SW4.

## 4-1. Tower Names and Setting the DIP Switches

In setting a tower name to the installed devices, the DIP SW1 is set on each tower as follows:

<Setting the DIP SW1>

Tower A	Tower B	Tower C	Tower D	Tower E	Tower F
<p>DIP SW1</p>	<p>DIP SW1</p>	<p>DIP SW1</p>	<p>DIP SW1</p>	<p>DIP SW1</p>	<p>DIP SW1</p>

**4-2. Connecting the Towers and Setting the DIP Switches**

DIP SW is set on Tower A. Connect the towers as follows:

<Setting the DIP SW1>

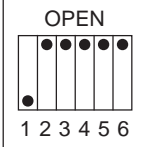
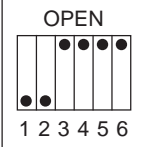
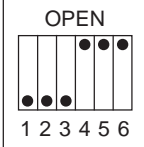
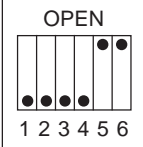
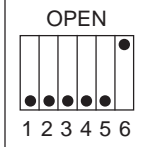
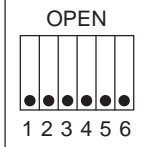
Tower A only	Towers A & B	Towers A, B & C	Towers A, B, C & D	Towers A, B, C, D & E	Towers A, B, C, D, E & F
 <p>DIP SW1</p>	 <p>DIP SW1</p>	 <p>DIP SW1</p>	 <p>DIP SW1</p>	 <p>DIP SW1</p>	 <p>DIP SW1</p>

### 4-3. Selecting the Functions

- The following functions are selected with the DIP SW2.

<Factory setting>

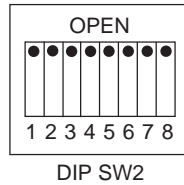

SW No.	Functions	Setting the switch		Factory setting
		Down (numerals)	Up (open)	
1	DC-8000S ST	Yes	No	Up
2	DC-8000S ST sideways vibration	Yes	No	Up
3	Use of LU-HM manual feed unit (A)	Yes	No	Up
4	Use of LU-HM SW (Valid when switch 3 is set to the "numerals" side.) (A)	Yes	No	Up
5	Change in LU-HM solenoid timing (A)	Yes	No	Up
6	Connecting DBM-200 (A)	Yes	No	Up
7	Not used			Up
8	Double-feed detection % switching	Yes	No	Up

\* LU-HM timing adjustment ..... shift + 0

Initial value: 3

When the switch is pressed, switches in the following order. 4→5→6→7→8→1→2→3

Double-feed detection % switching ..... shift + 4

Initial value: 20%

When the switch is pressed, switches in the following order. 25% → 33% → 50% → 12% → 16% → 20%

\* (A) indicates that only the settings for tower A are valid.

The following functions are selected with the DIP SW3.

<Factory setting>

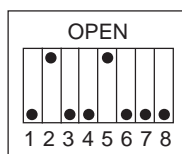

DIP SW3

SW No.	Functions	Setting the switch		Factory setting
		Down (numerals)	Up (open)	
1	Buzzer sounds when ended in error	Yes	No	Down
2	Counter repeated (A)	Yes	No	Up
3	Conveyance jam detection	Yes	No	Down
4	Separator B used	Yes	No	Down
5	Not used			Up
6	Stops at paper feed error set? (A)	2 sets	1 set	Down
7	Ejected to side ? when reset (A)	Downstream processing machine	Reject tray	Down
8	Main clutch turns on simultaneously (A)	No	Yes	Down

\* (A) indicates that only the settings for tower A are valid.

#### 4. FUNCTIONS OF THE DIP SWITCHES AND THEIR USE

The following functions are selected with the DIP SW4.

A feed error detecting device is built into the conveyance way on each paper feed bin.

The DIP SW4 is used to detect whether the paper feed error detection function (detecting a double-feed, mis-feed or paper jam) is effective or not.

This function is selected on each tower.

<Factory setting>

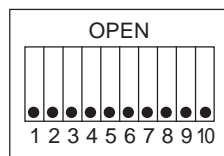

DIP SW4

SW No.	Functions	Setting the switch		Factory setting
		Down (numerals)	Up (open)	
1	Paper feed error detection function on paper feed bin No. 1	Effective	Ineffective	Down
2	Paper feed error detection function on paper feed bin No. 2	Effective	Ineffective	Down
3	Paper feed error detection function on paper feed bin No. 3	Effective	Ineffective	Down
4	Paper feed error detection function on paper feed bin No. 4	Effective	Ineffective	Down
5	Paper feed error detection function on paper feed bin No. 5	Effective	Ineffective	Down
6	Paper feed error detection function on paper feed bin No. 6	Effective	Ineffective	Down
7	Paper feed error detection function on paper feed bin No. 7	Effective	Ineffective	Down
8	Paper feed error detection function on paper feed bin No. 8	Effective	Ineffective	Down
9	Paper feed error detection function on paper feed bin No. 9	Effective	Ineffective	Down
10	Paper feed error detection function on paper feed bin No. 10	Effective	Ineffective	Down

# 5. SELECTING THE PAPER EJECTION DIRECTION

Select the paper ejection direction: to the right or left.

- The left ejection is initially set and displayed when the power is turned on.

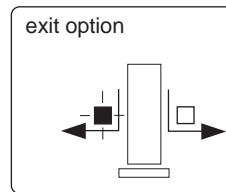

- Every time the “6” key on the keypad is pressed with the shift key held down, the paper ejection direction is switched and the display shows right or left repeatedly.

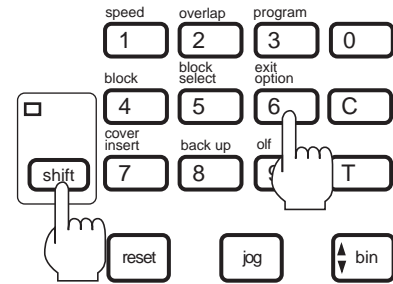

\* When DC-8000S RD is not connected, it will not be switched.

- When the right ejection is selected with two or more towers connected, only the paper on the last connected tower is ejected to the right.

The paper on the other connected bins is not fed.

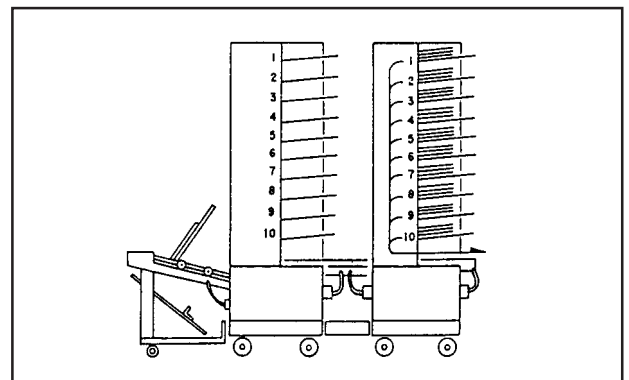

- The block mode and some of the program modes cannot be used when the right ejection is selected.

Refer to the list below.

		Program mode				
		Auto	5-bin	10-bin	Alt all	Alt cover
Block mode	off	○	×	×	○	○
	1/2	○	×	×	×	×
	1/3	×	×	×	×	×
	1/4	×	×	×	×	×

○=can be set    ×=cannot be set

# 6. SETTING THE PROGRAM MODE AND THE BLOCK MODE

Some of the program modes and block modes cannot be used according to tower connecting conditions.

The following are connected towers and the availability of setting the modes

## ■ In the case of Tower A only

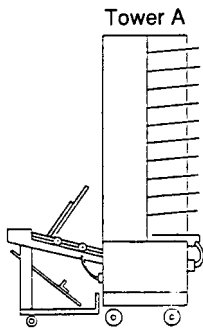

program

auto  5bin  10bin  alt all  alt cover

block

off  1/2  1/3  1/4

		Program mode				
		Auto	5-bin	10-bin	Alt all	Alt cover
Block mode	off	<input type="radio"/>	<input type="radio"/>	×	<input type="radio"/>	<input type="radio"/>
	1/2	<input type="radio"/>	×	×	×	×
	1/3	×	×	×	×	×
	1/4	×	×	×	×	×

○=can be set    ×=cannot be set

## ■ In the case of Towers A and B

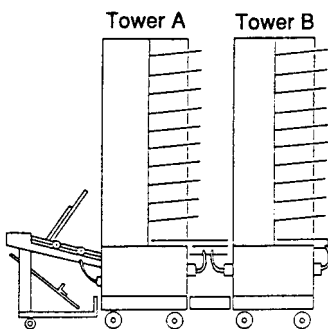

program

auto  5bin  10bin  alt all  alt cover

block

off  1/2  1/3  1/4

		Program mode				
		Auto	5-bin	10-bin	Alt all	Alt cover
Block mode	off	<input type="radio"/>	<input type="radio"/>	<input type="radio"/>	<input type="radio"/>	<input type="radio"/>
	1/2	<input type="radio"/>	<input type="radio"/>	×	<input type="radio"/>	<input type="radio"/>
	1/3	×	×	×	×	×
	1/4	<input type="radio"/>	×	×	×	×

○=can be set    ×=cannot be set

■ In the case of Towers A, B and C

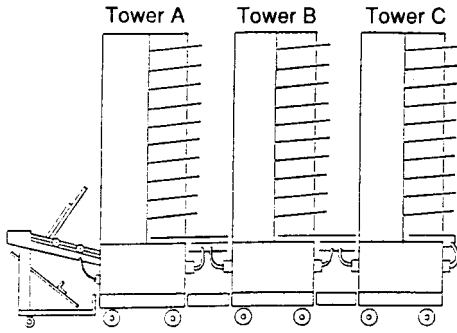

program

auto  5bin  10bin  alt all  alt cover

block

off  1/2  1/3  1/4

		Program mode				
		Auto	5-bin	10-bin	Alt all	Alt cover
Block mode	off	<input type="checkbox"/>	<input type="checkbox"/>	<input type="checkbox"/>	<input type="checkbox"/>	<input type="checkbox"/>
	1/2	<input checked="" type="checkbox"/>	<input checked="" type="checkbox"/>	<input checked="" type="checkbox"/>	<input checked="" type="checkbox"/>	<input checked="" type="checkbox"/>
	1/3	<input type="checkbox"/>	<input type="checkbox"/>	<input checked="" type="checkbox"/>	<input type="checkbox"/>	<input type="checkbox"/>
	1/4	<input checked="" type="checkbox"/>	<input checked="" type="checkbox"/>	<input checked="" type="checkbox"/>	<input checked="" type="checkbox"/>	<input checked="" type="checkbox"/>

○=can be set    ×=cannot be set

■ In the case of Towers A, B, C and D

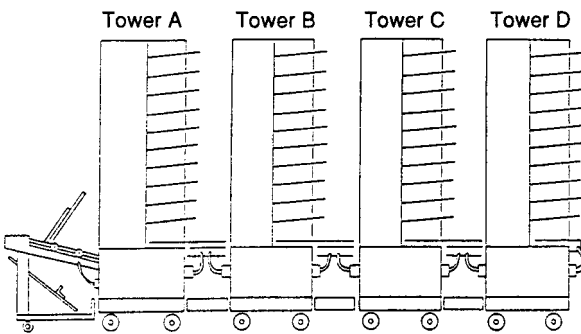

program

auto  5bin  10bin  alt all  alt cover

block

off  1/2  1/3  1/4

		Program mode				
		Auto	5-bin	10-bin	Alt all	Alt cover
Block mode	off	<input type="checkbox"/>	<input type="checkbox"/>	<input type="checkbox"/>	<input type="checkbox"/>	<input type="checkbox"/>
	1/2	<input type="checkbox"/>	<input type="checkbox"/>	<input type="checkbox"/>	<input type="checkbox"/>	<input type="checkbox"/>
	1/3	<input checked="" type="checkbox"/>	<input checked="" type="checkbox"/>	<input checked="" type="checkbox"/>	<input checked="" type="checkbox"/>	<input checked="" type="checkbox"/>
	1/4	<input type="checkbox"/>	<input type="checkbox"/>	<input checked="" type="checkbox"/>	<input type="checkbox"/>	<input type="checkbox"/>

○=can be set    ×=cannot be set



6. SETTING THE PROGRAM MODE AND THE BLOCK MODE

■ In the case of Towers A, B, C, D and E

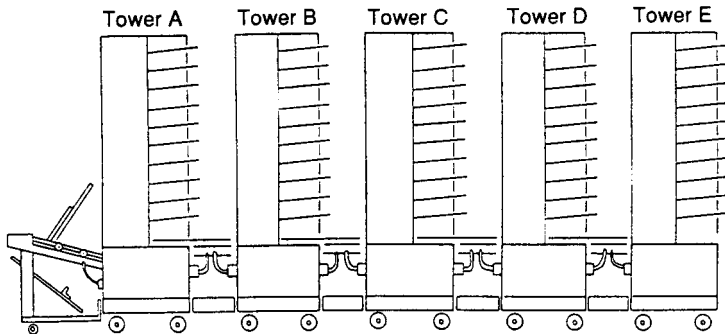

		Program mode				
		Auto	5-bin	10-bin	Alt all	Alt cover
Block mode	off	○	×	×	×	○
	1/2	×	×	×	×	×
	1/3	×	×	×	×	×
	1/4	×	×	×	×	×

○=can be set    ×=cannot be set

■ In the case of Towers A, B, C, D, E and F

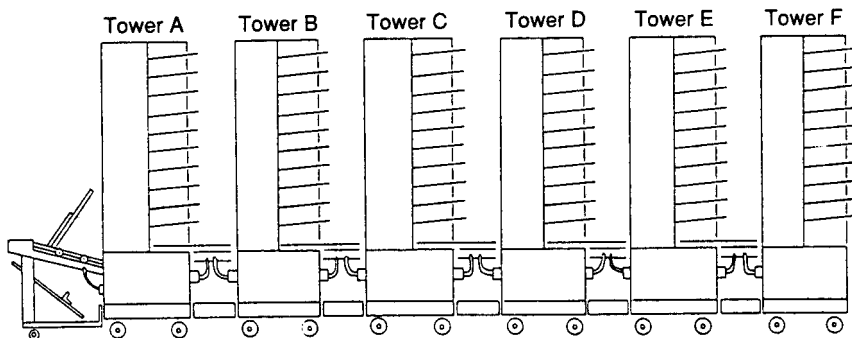

		Program mode				
		Auto	5-bin	10-bin	Alt all	Alt cover
Block mode	off	○	×	×	×	○
	1/2	×	×	×	×	×
	1/3	×	×	×	×	×
	1/4	×	×	×	×	×

○=can be set    ×=cannot be set

■ In the case of the right ejection

		Program mode				
		Auto	5-bin	10-bin	Alt all	Alt cover
Block mode	off	○	×	×	○	○
	1/2	○	×	×	×	×
	1/3	×	×	×	×	×
	1/4	×	×	×	×	×

○=can be set    ×=cannot be set

# 7. FUNCTIONS OF THE PROGRAM MODES AND THEIR USE

Five kinds of functions are programmed for the paper feed method in this collator system. Select a most suitable program mode according to conditions.

If the program mode is used when there are only a few collating pages, the processing speed will increase.

- “Auto” mode is set when the power is turned on.
- Press the “3” key on the keypad with the shift key held down to select the program mode.
- Every time the “3” key on the keypad is pressed, the program mode display shows 5-bin, 10-bin, alt all, alt cover Auto and repeats them.

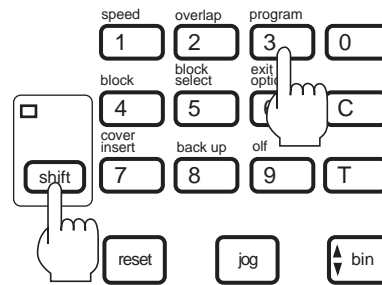
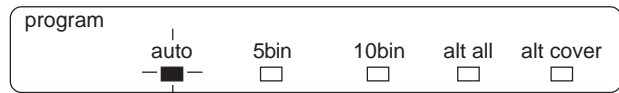

**NOTE** : Depending on tower connecting conditions, some of the program modes cannot be selected. For further details, refer to “6. SETTING THE PROGRAM MODE AND THE BLOCK MODE”.

## 7-1. Auto Mode

All the sheets of paper on the paper feed bins are fed.

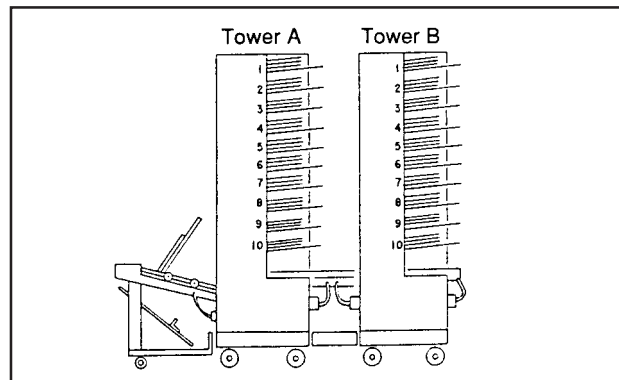
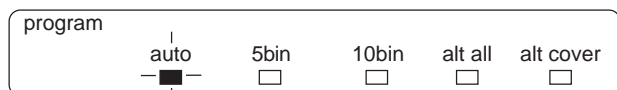

## 7-2. 5-Bin Mode

All the paper feed bins are divided into blocks one of which consists of 5 bins, to feed and process paper on the 5 bins as a block. This mode is suitable for printed matter of 5 pages or less.

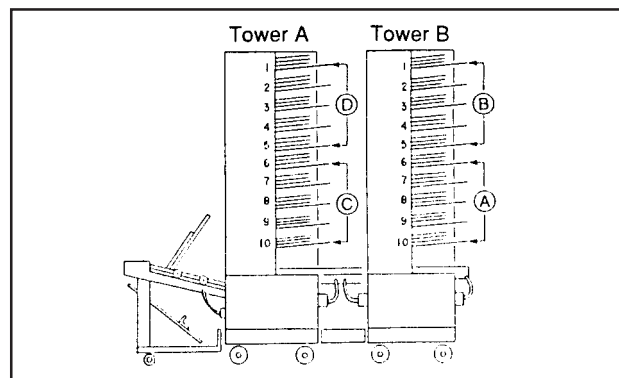

### 7-3. 10-Bin Mode

All the bins are divided into blocks (one block consists of 10 bins) to feed and process paper on the 10 bins as a block.

This mode is suitable for printed matter of 10 pages or less.

program				
auto	5bin	10bin	alt all	alt cover
<input type="checkbox"/>	<input type="checkbox"/>	<input checked="" type="checkbox"/>	<input type="checkbox"/>	<input type="checkbox"/>

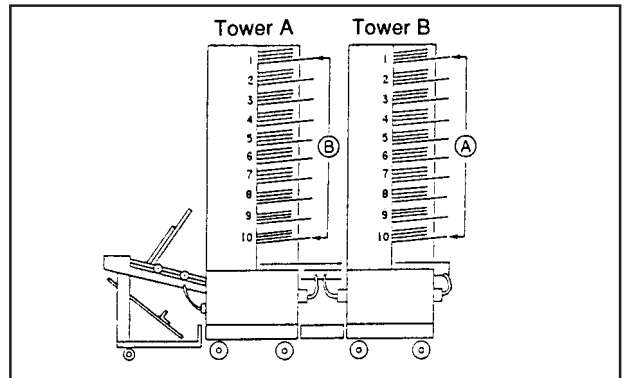

### 7-4. Alt All Mode

- The paper is fed from either bin of a pair consisting of an even and uneven number of bins.

The paper is fed preferentially from the upper bin.

program				
auto	5bin	10bin	alt all	alt cover
<input type="checkbox"/>	<input type="checkbox"/>	<input type="checkbox"/>	<input checked="" type="checkbox"/>	<input type="checkbox"/>

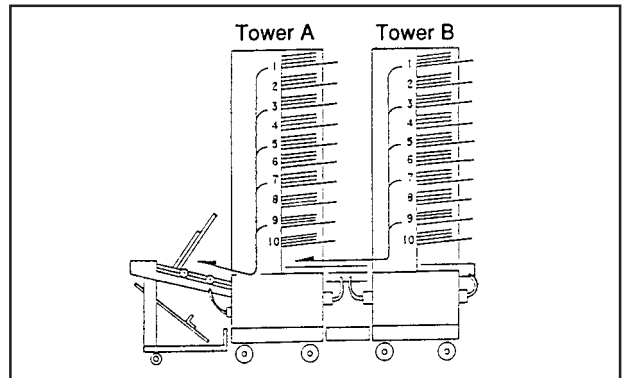

- Feeding is switched to the lower bin when the paper runs out on the upper bin.

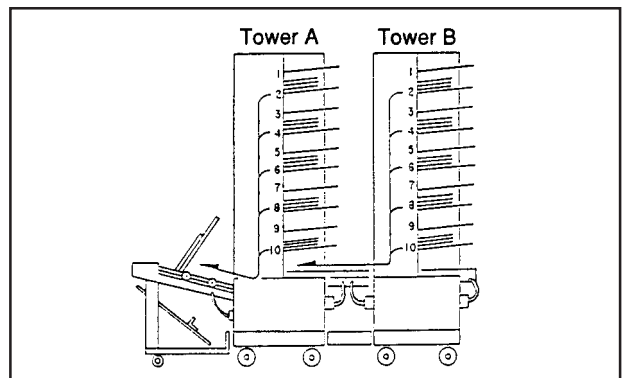

## 7-5. Alt Cover Mode

- The paper is fed from either of paper feed bin No. 1 or No. 2.
- The paper is fed preferentially from bin No. 1, and feeding is switched to bin No. 2 when the paper runs out on bin No. 1.  
The paper on bin No. 3 or the following is fed accordingly in order.

program				
auto	5bin	10bin	alt all	alt cover
<input type="checkbox"/>	<input type="checkbox"/>	<input type="checkbox"/>	<input type="checkbox"/>	<input checked="" type="checkbox"/>

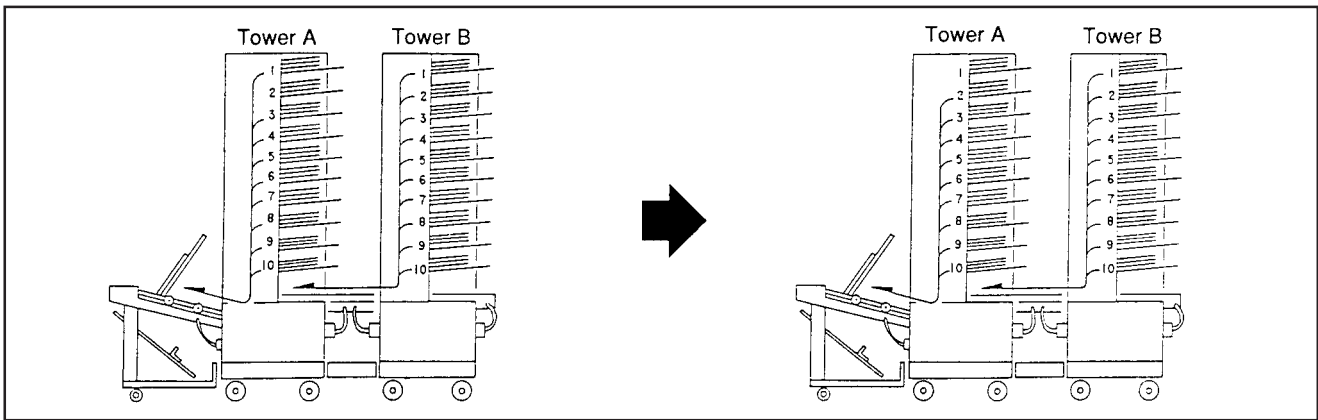

This is applicable to the heavy paper when it is used as a cover.  
Load paper on paper feed bin No. 1 or 2.

# 8. FUNCTIONS OF THE BLOCK MODES AND EXAMPLES OF THEIR USE

There are three block modes: 1/2 block mode, 1/3 block mode and 1/4 block mode.

All the feed bins are divided into the designated block by selecting the block mode (1/2, 1/3, 1/4), to commence feeding by block.

The time for placing the paper is shortened with this function when the number of sets to be collated is small. (While the machine is running, paper can be loaded in the block which is not working.)

Select a block mode referring to examples of the following cases.

## 8-1. Setting the Block Mode

- The block mode is off when the power is turned on.
- The “1/2” display lamp lights up and “1/2” block mode is set when “4” on the keypad is pressed with the shift key held down. Every time “4” on the keypad is pressed with the shift key held down, the block mode display shows 1/2, 1/3, 1/4, Off, and repeats them.

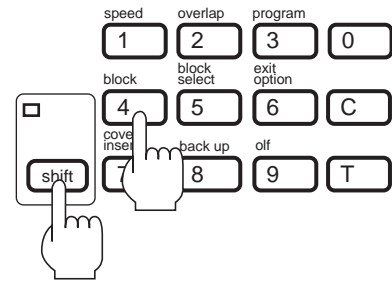

**NOTE** : Depending on connected tower conditions, some block modes are unusable. For further details, refer to “6. SETTING THE PROGRAM MODE AND THE BLOCK MODE”.

## 8-2. Example of Using the 1/2 Mode

**1** Press the “4” key on the keypad with the shift key held down to select the block mode.

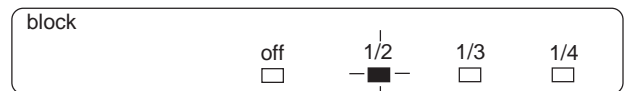

- In case 1/2 block mode is set:
- The paper feed bins are divided into two blocks, Nos. 1 and 2, to perform feeding by block.

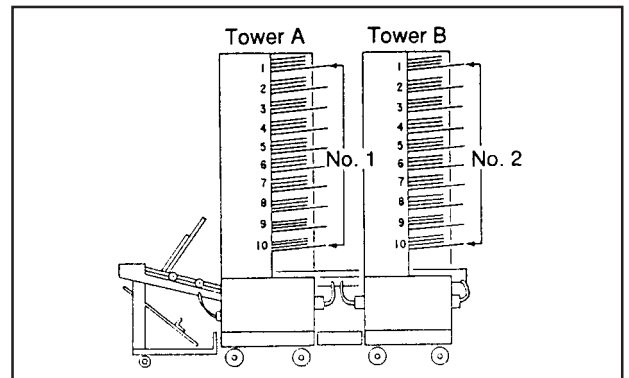

## 2 Designate from which block to commence operation.

- Commence operation from Tower A.
- Two block selection display lamps light up on Tower A, when the “5” key on the keypad is pressed with the shift key held down.

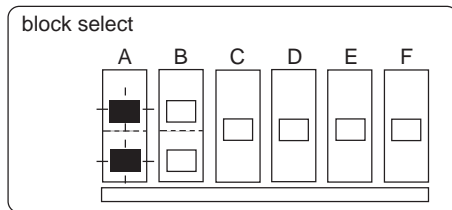
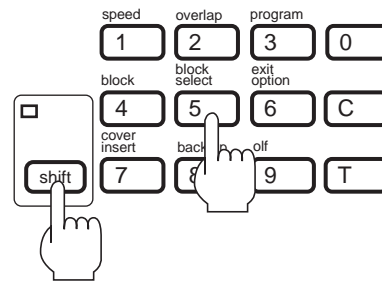

- Collation starts to be processed from block No. 1 on Tower A when the start key is pressed.

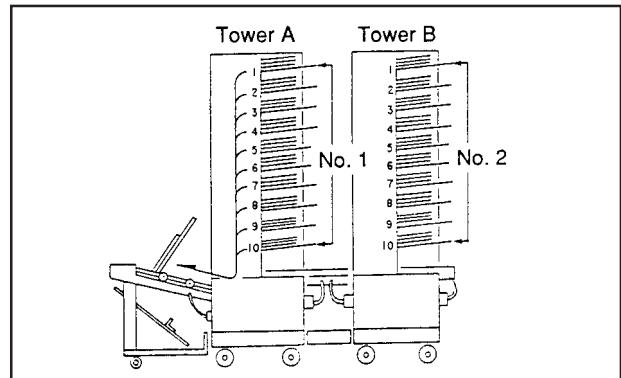

- When the paper runs out on block No. 1, the machine stops and the block selection display is switched to Tower B.
- Press the start key to restart operation in block No. 2.

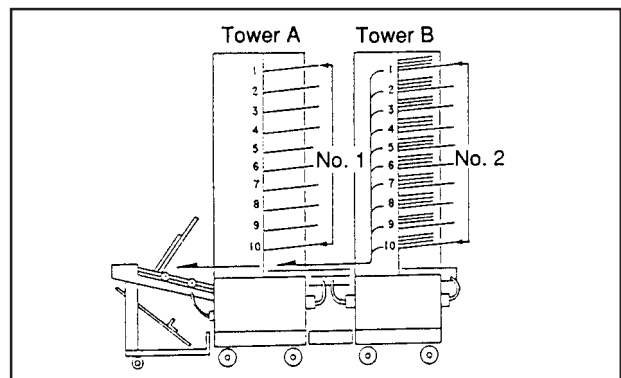
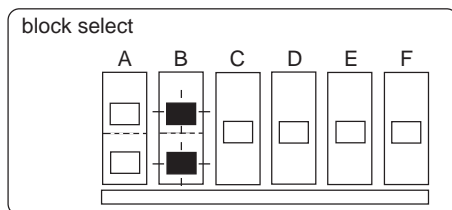

**8-3. Example of Using the 1/4 Mode**

**1** Press the “4” key on the keypad with the shift key held down to set the block mode to “1/4”.

- All the bins are divided into 4 blocks Nos. 1 to 4 to feed and process the paper on the feed bins by block as shown in the figure.

block

off	1/2	1/3	1/4
<input type="checkbox"/>	<input type="checkbox"/>	<input type="checkbox"/>	<input checked="" type="checkbox"/>

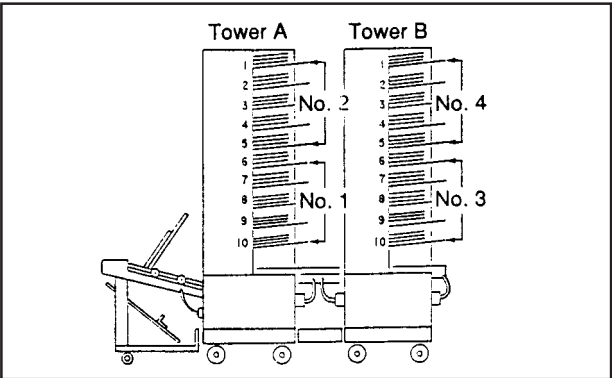



## 2 Designate from which block to commence operation.

- Commence operation from block No. 1
- When the “5” key on the keypad is pressed with the shift key held down, the lower block selection lamp (Block No. 1) on Tower A lights up.
- Collation starts to be processed from block No. 1 on Tower A when the start key is pressed.

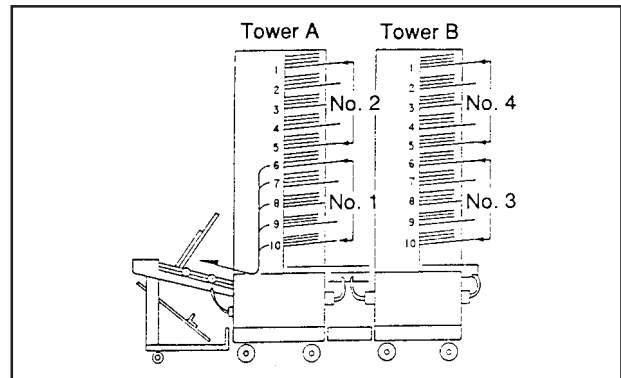
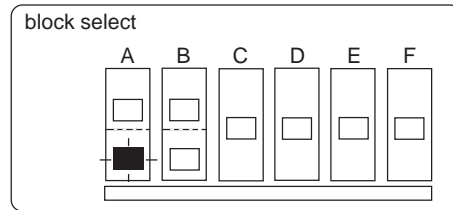

- When the paper runs out in block No. 1, the machine stops and the block selection display is switched to the upper block (block No. 2) on Tower A.
- Press the start key to restart collation in block No. 2.
- When the paper runs out in the block, the block display shows No. 1, No. 2, No. 3, No. 4, and then repeats them.

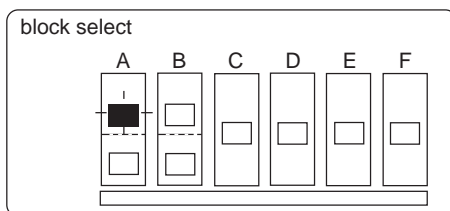
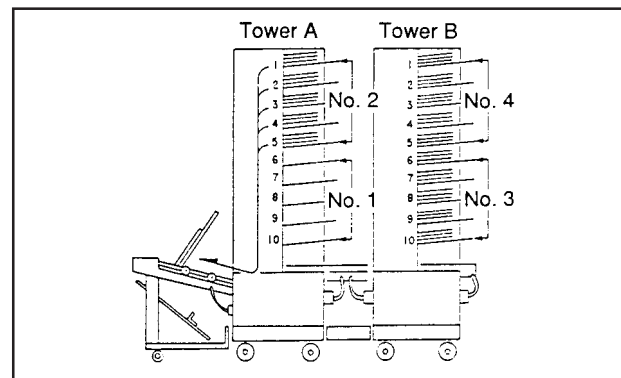

### 8-4. Example of Using the 1/3 Mode

This mode is set when three towers are connected.

**1** Press the “4” key on the keypad with the shift key held down to set the block mode to “1/3”.

- All the bins are divided into 3 blocks Nos. 1 to 3 to feed and process the paper on the feed bins by block.

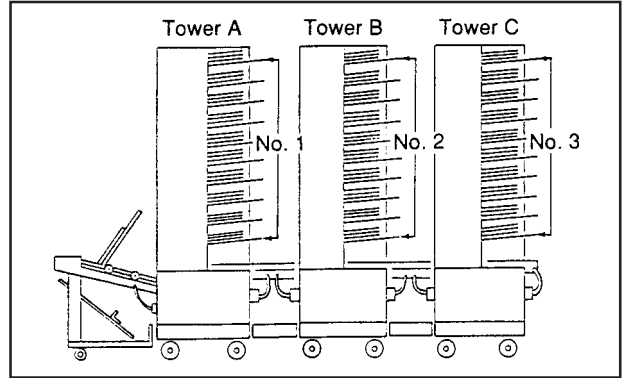
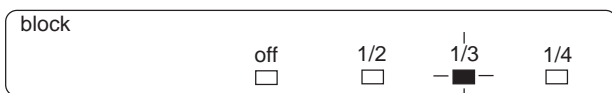

## 2 Designate from which block to commence operation.

- Commence operation from block No. 1.
- When the “5” key on the keypad is pressed with the shift key held down, the blocks are selected in the order  $\rightarrow B \rightarrow C \rightarrow A$  each time the key is pressed.
- Collation starts to be processed from block No. 1 on Tower A when the start key is pressed.

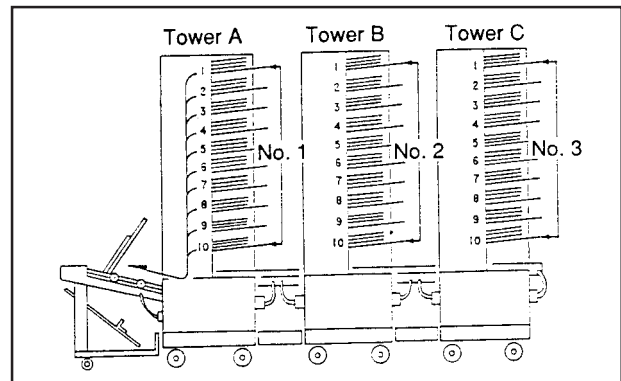
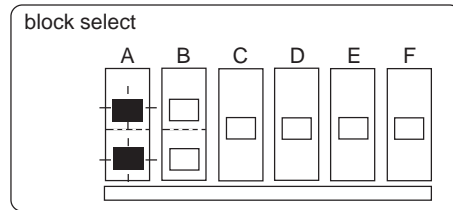

- When the paper runs out in block No. 1, the machine stops and the block selection display is switched to Tower B (block No. 2).
- Press the start key to restart collation in block No. 2.
- Every time the paper runs out in the block, the block display shows No. 1, No. 2, No. 3, then repeats.

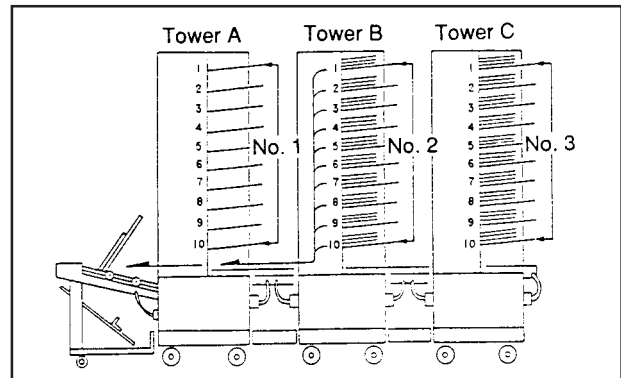
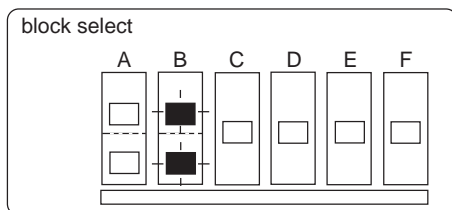

# 9. USING THE COVER INSERT MODE

This mode is used to collate printed matter with a cover.

## 9-1. Setting the Cover Insert Mode

This mode is initially set OFF when the power is turned on.

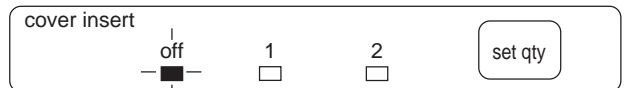

**1** Set the program mode to “Auto” mode.

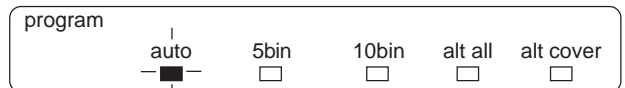

**2** Press the “7” key on the keypad with the shift key held down to select any mode.

- Every time the “7” key on the keypad is pressed with the shift key held down, the display shows OFF, 1, 2, then repeats.
- When the cover insert mode 1 is selected, one sheet of cover paper is inserted as shown in the figure.

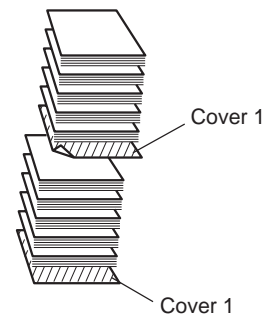
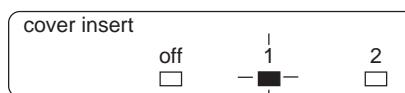
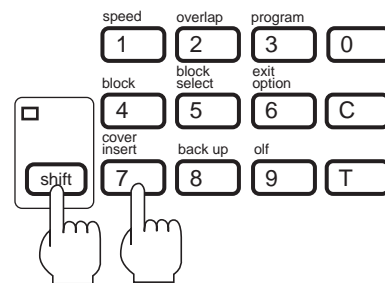

- When the cover insert mode 2 is selected, two sheets of cover paper are inserted as shown in the figure.

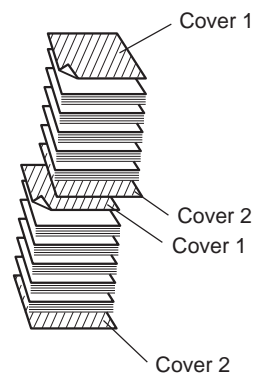
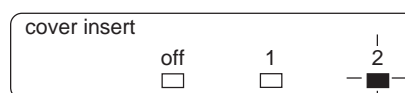

## 9-2. Setting When to Insert Cover

Determine the number of sets after which the cover paper is inserted.

**1** Input the number of sets on the keypad with the set qty key held down.

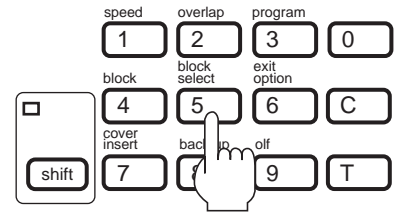
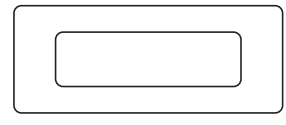
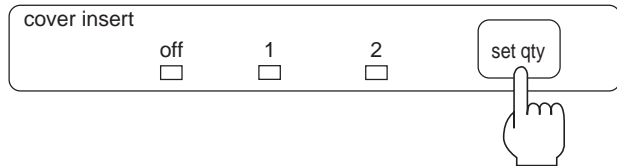

**2** For example, input 5 on the keypad to insert a cover into every 5 sets.

- The input number of sets is displayed on the display window while the set qty key is pressed.
- The maximum number of sets is 999.

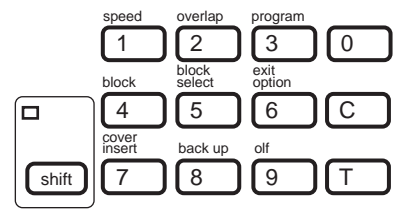
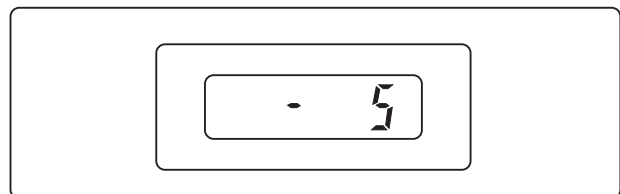

- When the cover insert mode is set to "1", the cover paper is inserted at the following intervals.
- When only one tower is used, one set consists of 9 sheets of paper.
- A sheet of cover paper is inserted into every 5 sets.

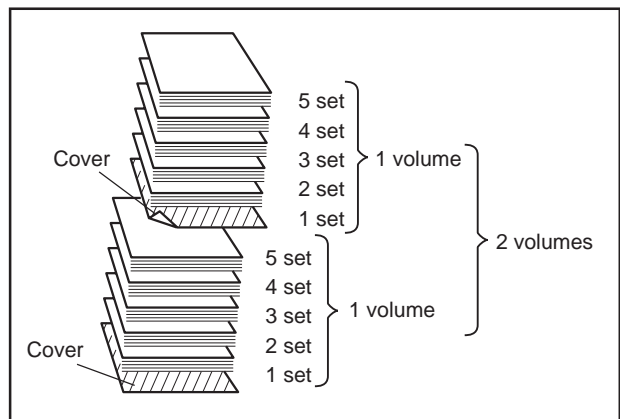

### 9-3. Setting the Number of Volumes to be Collated

Take the following procedures to input the number of volumes to be collated with cover inserted.

- Input the value of sets to be collated on the keypad.

Calculate the value to be input as follows.

$$\begin{array}{l} \text{Number of sets} \times \text{Required volumes} = \\ \text{Input value (Number of volumes processed)} \end{array}$$

For example, if 100 volumes of 5 sets (the cover is inserted after every 5 sets) are required, input 500 from the above equation.

- \* For the cover insert mode, the machine will stop if a paper feed error occurs in one set regardless of the setting of DIP SW3-6.

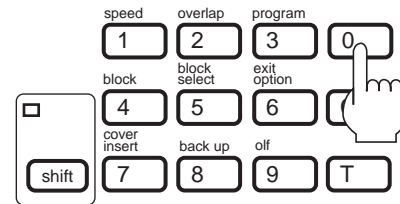
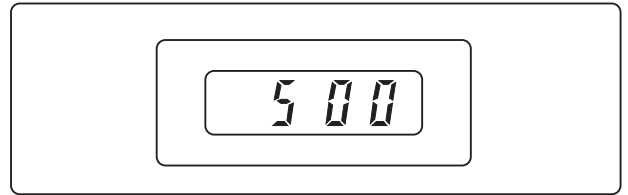

# 10. LOADING THE PAPER

---

## 10-1. Precautions to be Taken in Loading Paper

- Thick paper such as covers should be loaded on the first and second, or ninth and tenth bins.
- Make sure that the ink on the paper surface is dry.
- Be careful not to use the paper with wet ink on it as this may dirty the paper, ink rub off on the conveyance way and this may cause problem.
- Curled or folded paper should be flattened before use.
- The folded paper should be pressed even and be flattened before use.
- Stack the paper from the right side of the paper feed bin so that the paper does not damage the paper switch.

## 10-2. Loading Paper for the General Collation Operation

■ When only one tower is used:

**1** Load paper with the printed surface up.

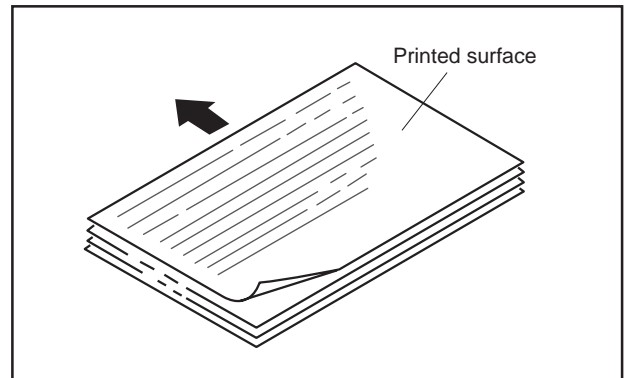

**2** When the number of sheets to be collated is 10, load the last page on bin No. 10 with the printed surface up, from the bottom in order.

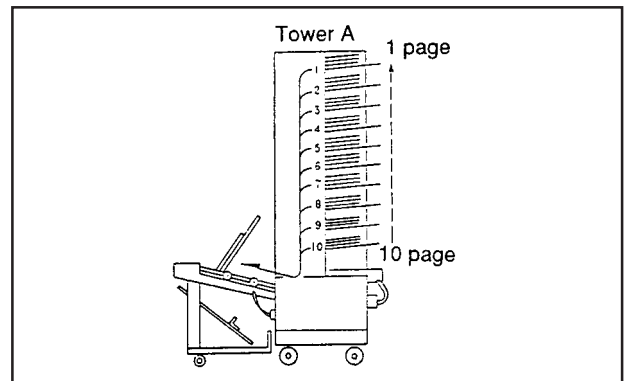

- As shown in the figure, load the last page on paper feed bin No. 1, from the top in order, when the right ejection mode is selected.
- Refer to “10-5. Precautions to be Taken in the Right Ejection Mode”

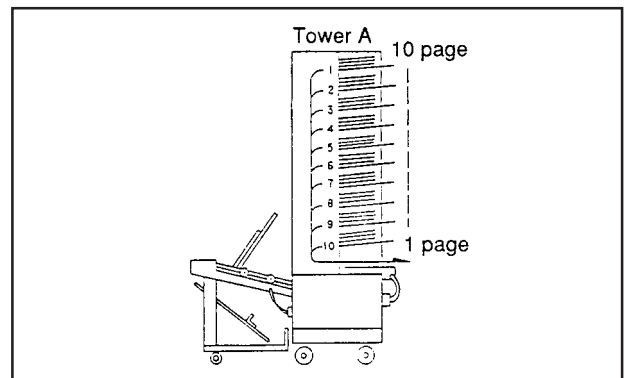



■ When two towers are connected

**1** When the number of sheets to be collated is 20, load the last page on bin No. 10 on Tower B from the bottom in order as shown in the figure.

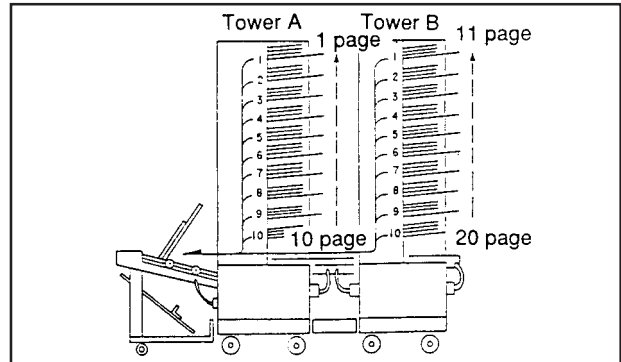

**2** When the number of sheets to be collated is 14, load paper as shown in the figure.

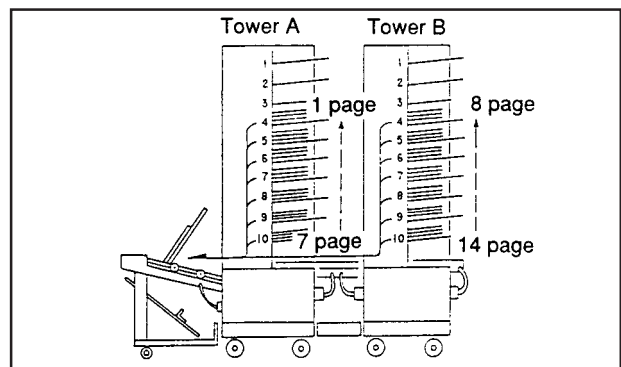

**10-3. Loading Paper for the Collation Operation with Cover Inserted**

■ Cover insert mode 1

**1** If a cover is inserted into every xxth sets one of which consists of 5 pages, load cover paper on the bottom bin.

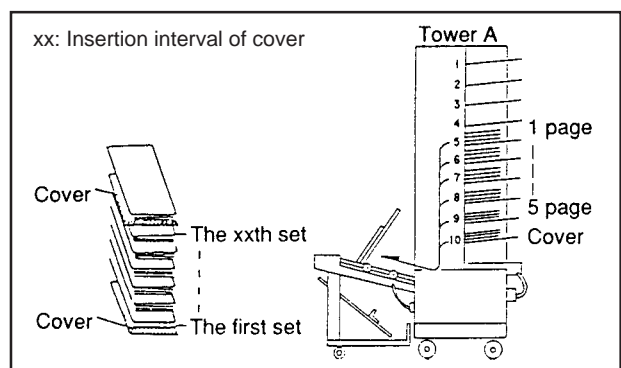

**2** When two or more towers are connected, also load the last page on the bottom bin of the last connected tower already containing paper.

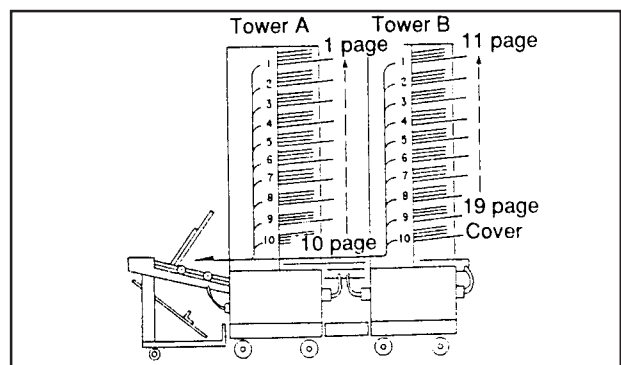

■ When the block mode is used

- The cover can be inserted by using the block mode function.
- Take the following procedures to set the block mode to “1/2” with two towers connected:

**1** Load cover paper on the bottom bin of each tower already containing paper as shown in the figure.

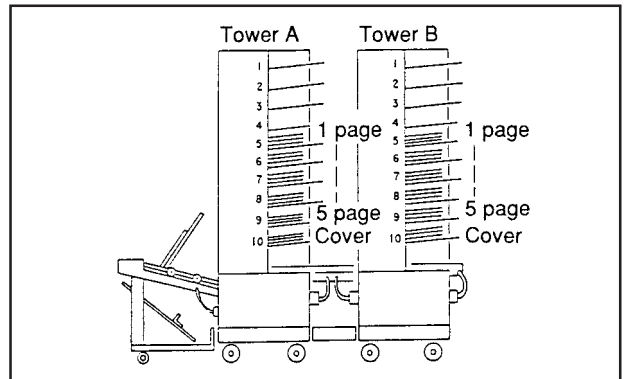

**2** Press the “5” key on the keypad with the shift key held down to designate the tower to operate.

- When Tower A is designated, collation operation start from Tower A.
- When the paper runs out on Tower A, the machine stops and collation operation is switched to Tower B.

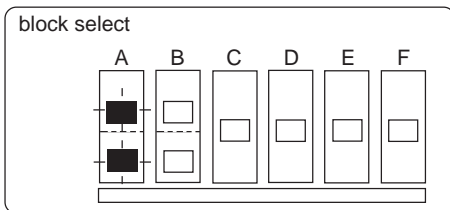
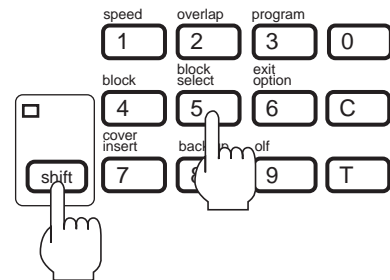

■ When the cover insert mode 2 is selected

- Load cover sheets on the upper and lower bins so that they are inserted to cover the top and bottom sets as shown in the figure.

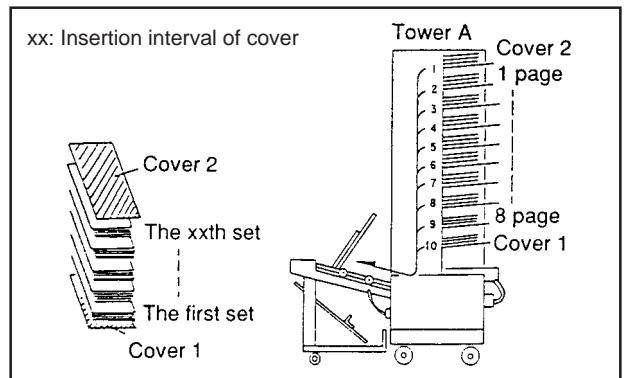

## 10-4. Precautions to be Taken in Loading Thick Paper

**1** Load thick paper on bins Nos. 1 and 2, 9 or 10 on the tower.

The following paper can be used: 157-250 g/m<sup>2</sup>

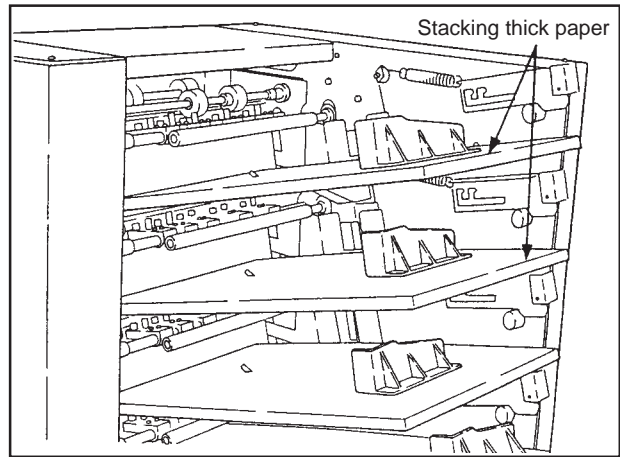

**2** Switch the conveyance pressure.

- There is a hole on the non-operating side frame as shown in the figure. Insert the hexagonal wrench into these holes and rotate it at an angle of about 180° in the clockwise direction.

**NOTE** : Do not attempt to insert the hexagonal wrench into the machine while it is working.

Return the conveyance pressure to its initial state when thick paper is replaced with normal paper. Conveyance pressure is set to the pressure for feeding normal paper at the factory.

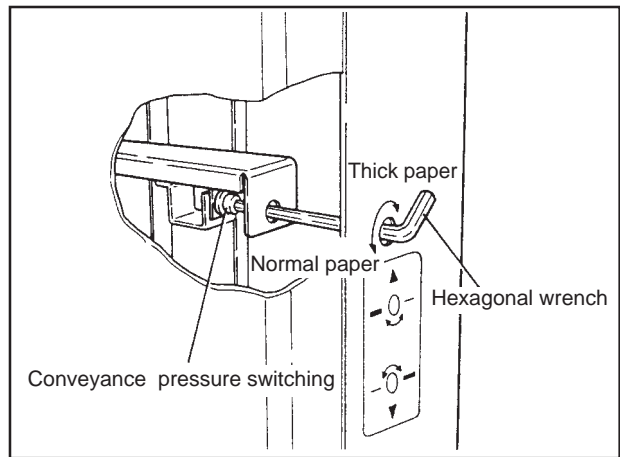

**3** Switch the double-feed sensitivity switch down on the bin on which thick paper is loaded.

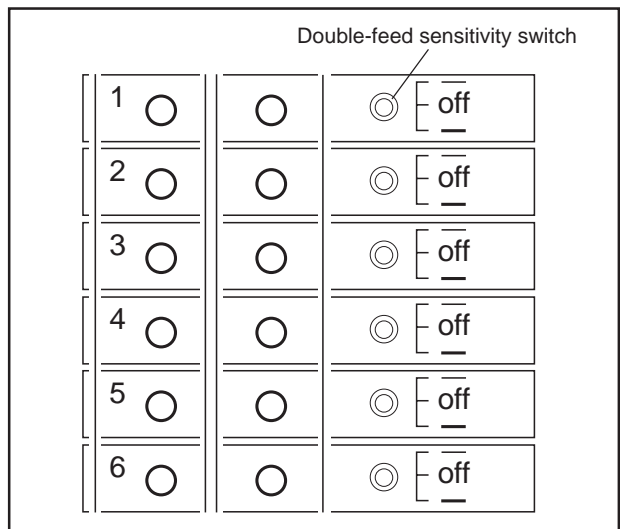

**10-5. Precautions to be Taken in the Right Ejection Mode**

When this mode is selected, the paper is ejected reversely and the printed surface is down.

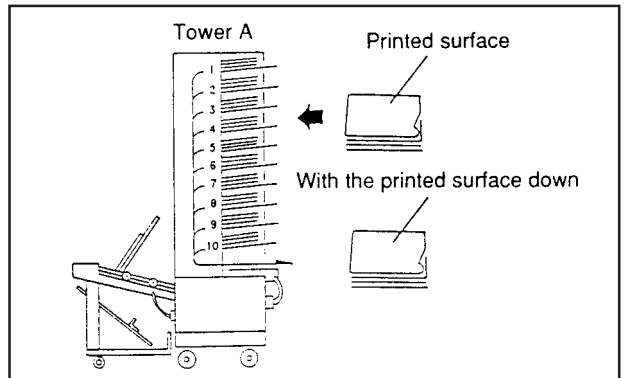
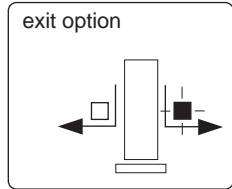

# 11. OPERATION PROCEDURES

---

- 1 Connect the power supply for the dry pump.

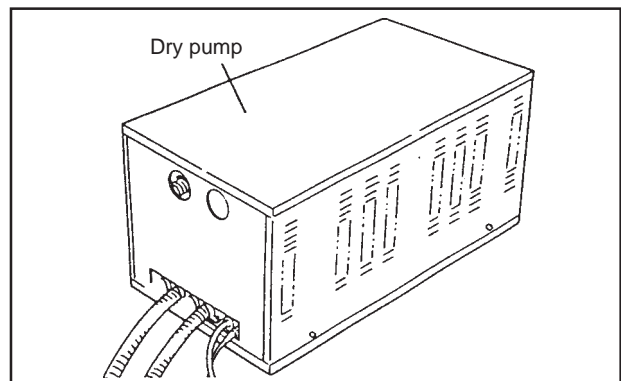

- Connect the communication cord of the pump to the collator.

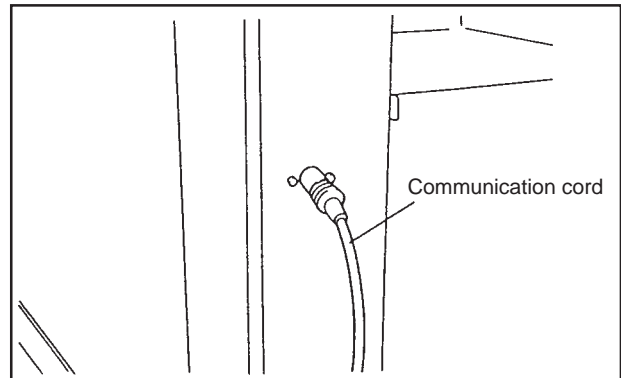

- 2 Connect the power supply for each tower main body.

- 3 Turn the power for each tower ON.

**NOTE** : Turn the power for Tower A ON last.

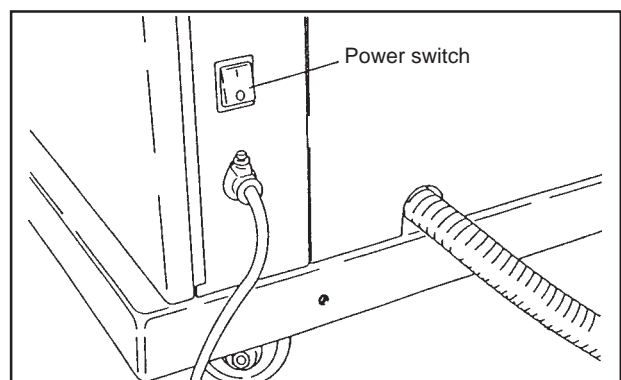

# 4 Switch the valve opening/closing according to paper size.

- Refer to the list of the valve opening/closing.

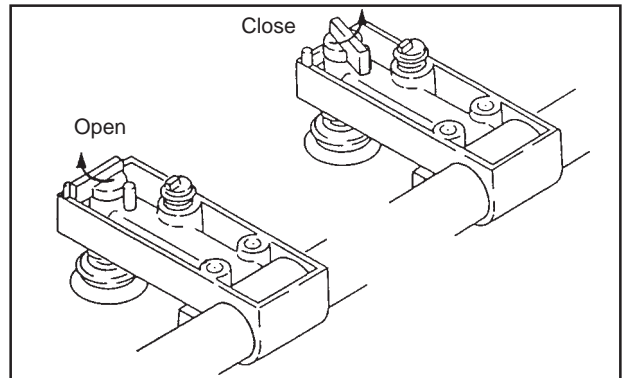

- There are five valves as shown in the figure.
- The state of the valve opening/closing is shown below.

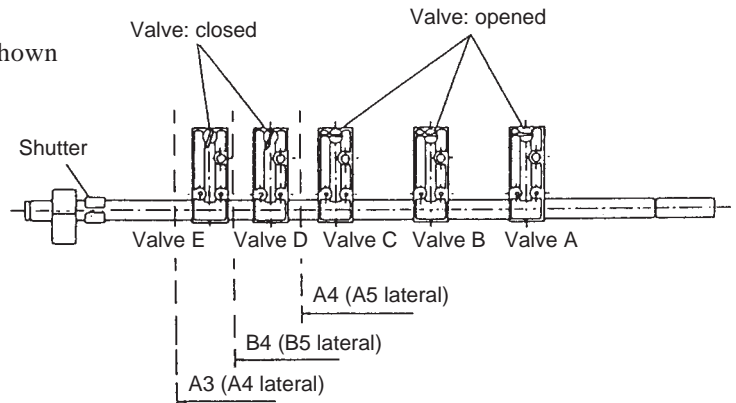

## <Valve opening/closing>

Valve	A5 lateral feeding	A4 longitudinal feeding	A3 longitudinal feeding	A3SR longitudinal feeding	B5 lateral feeding	B4 longitudinal feeding
A	○	○	○	○	○	○
B	○	○	○	○	○	○
C	○	○	○	○	○	○
D	×	×	×	×	○	○
E	×	×	○	○	×	×

Valve	Invoice lateral feeding	Letter longitudinal feeding	Double letter longitudinal feeding	Legal longitudinal feeding
A	○	○	○	○
B	○	○	○	○
C	○	○	○	○
D	×	×	○	×
E	×	×	×	×

○: switch to open    ×: switch to close

**5** Move the sub-guide's position according to paper size.

**NOTE** : Insert the sub-guide into the same position on the upper and lower stays.

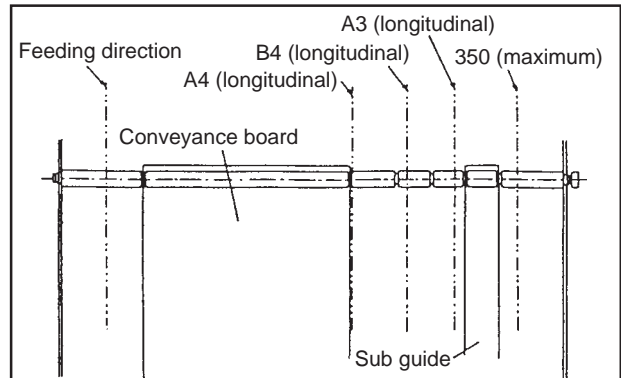

**6** Move the reject tray stopper position according to paper size.

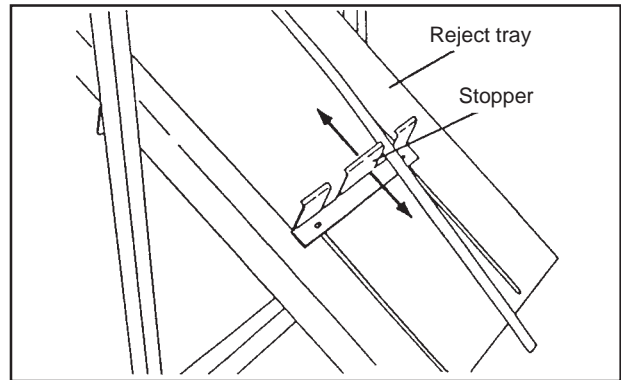

**7** Set the paper guide to the standard position "Level 3".

- Adjust the paper guide according to paper feeding conditions as follows:

Standard position: "Level 3"  
 When mis-feed occurs: "Level 2" or "Level 1"  
 When a double-feed occurs: "Level 4"

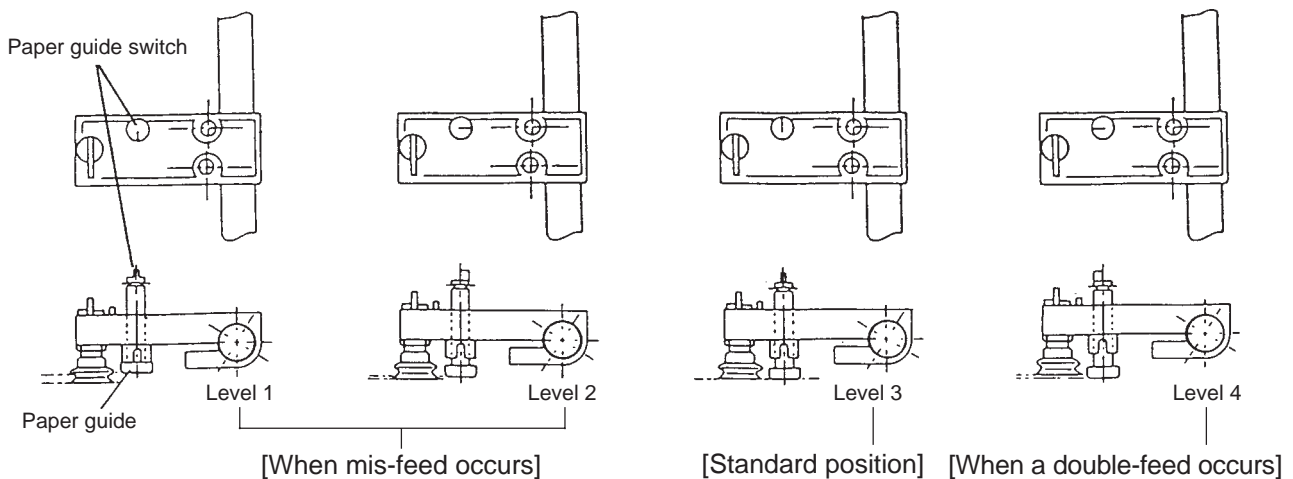

## 8 Adjust pad height with the adjusting knob.

- Adjust the suction pad position so that the pad is in the center of the brush and the paper feed bin.
- The pad goes up when the knob is rotated in the clockwise direction, and it goes down when the knob is rotated in the counterclockwise direction.

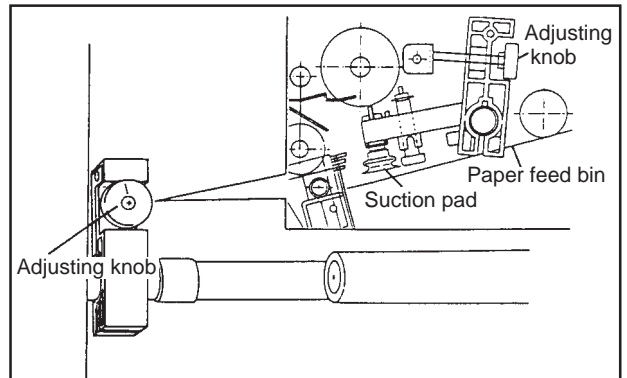

- Move the suction pad up little by little by rotating the knob in the clockwise direction when a double-feed occurs.

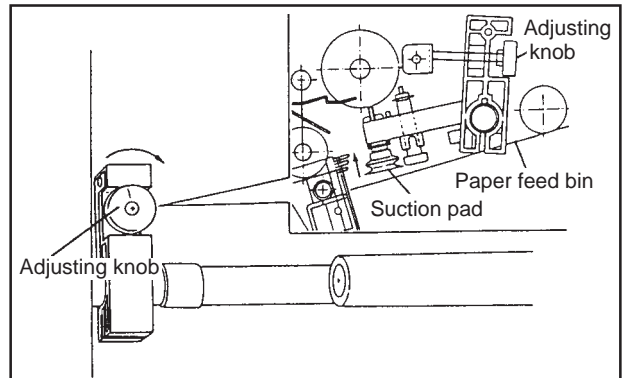

- Move the suction pad down little by little by rotating the knob in the counterclockwise direction when mis-feed occurs.

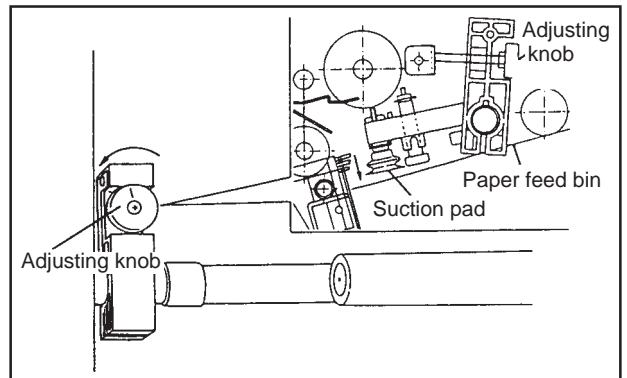



**9** Determine the bin pressure switch lever position according to paper quality.

- Set the lever position referring to the list below.

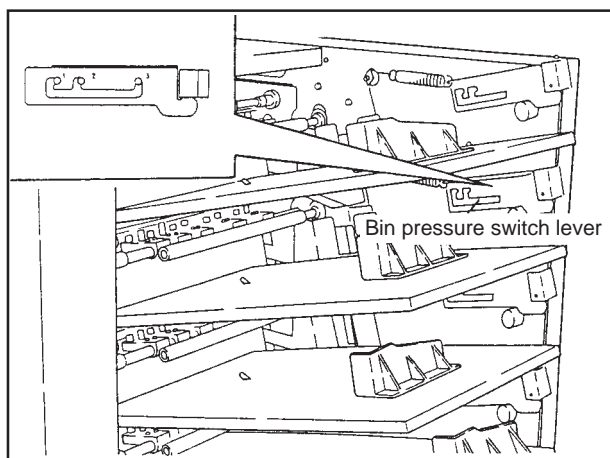

List for setting the bin pressure switch lever

	Fine quality paper			
<b>Paper size</b>	A4 52.3 g/m <sup>2</sup>	A4 157g /m <sup>2</sup>	A3 52.3 g/m <sup>2</sup>	A3 157 g/m <sup>2</sup>
<b>Setting bin pressure</b>	3	3	3	3

\* The standard bin pressure is the pressure with paper of 55 mm loaded on the bin.

	Coated paper			
<b>Paper size</b>	A4 79.1 g/m <sup>2</sup>	A4 157 g/m <sup>2</sup>	A3 79.1 g/m <sup>2</sup>	A3 157 g/m <sup>2</sup>
<b>Setting bin pressure</b>	3	3	2	2

**10** Close the three holes with the shutter.

- Slide the shutter sideways and open the hole step by step to adjust the suction pressure when a double-feed occurs.

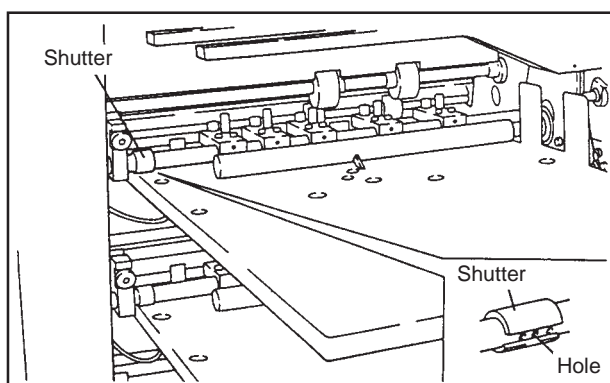

- 11** Press the paper feed bin key to lower the paper feed bin.

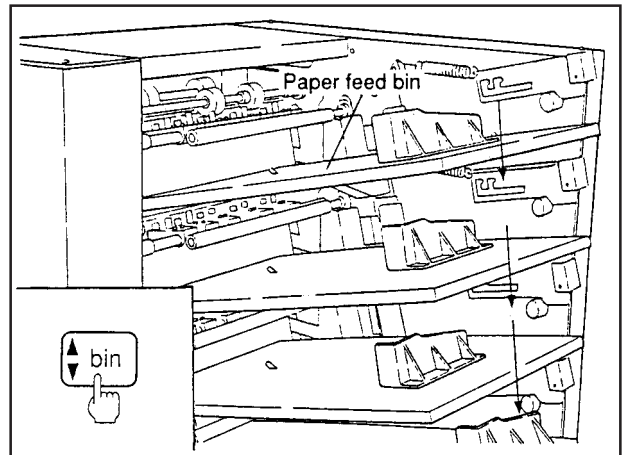

- 12** Load paper

- Load paper with the tip of the paper in contact with the guide plate after it is separated.
- Attach the corner guide lightly to the rear end of the paper as shown in the figure.

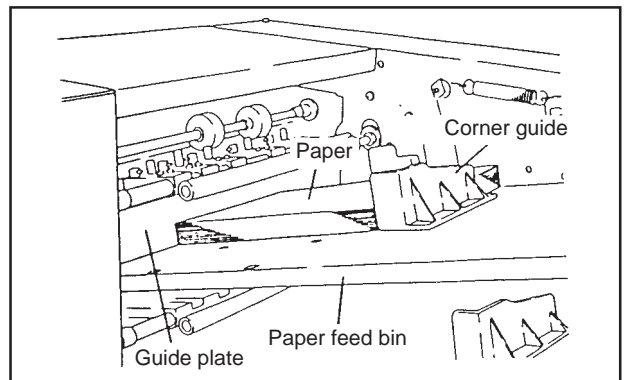

- 13** Press the paper feed bin key to lift the paper feed bin.

**NOTE** : Make sure that the paper on the bin is in contact with the stopper when the paper feed bin moves up and stops in the top limit position.

If the paper on the bin is not in contact with the stopper, increase the bin pressure.

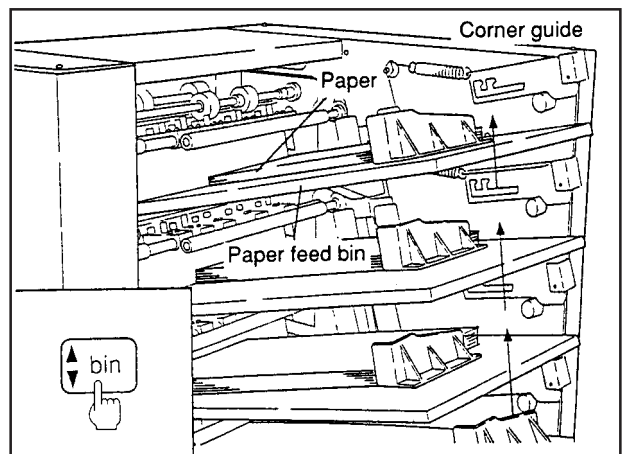

**14** Processing speed is set to the maximum when the power is turned on. Adjust the processing speed according to paper ejection conditions.

- Press the “1” key on the keypad with the shift key held down to switch the processing speed.
- Every time the “1” key is pressed, the display is switched to the direction of (-).

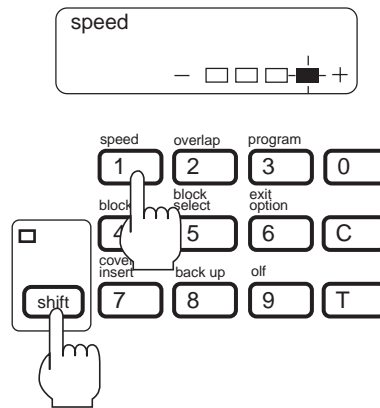

**15** Determine the paper ejection direction.

- The ejection direction is initially set to the left when the power is turned on.
- Press the “6” key on the keypad with the shift key held down to switch paper ejection direction.
- Every time the “6” key is pressed, the paper ejection direction is switched.

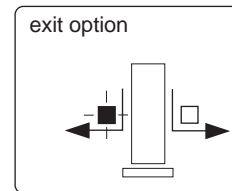

**16** Determine the program mode.

- The mode is initially set to the “auto”, when the power is turned on.
- Press the “3” key on the keypad with the shift key held down to switch the mode.
- Every time the “3” key is pressed, the mode is switched.

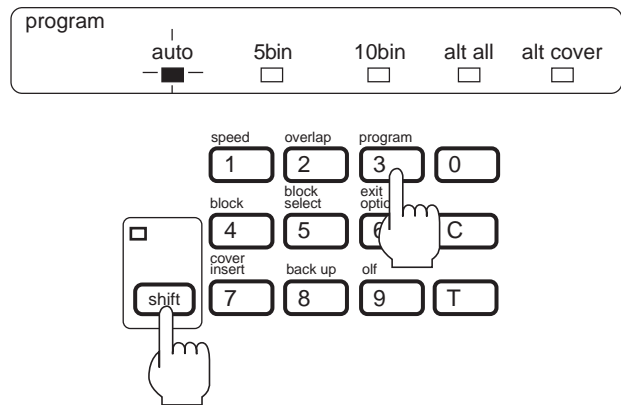

**17** Determine the block mode.

- The block mode is set to “off” when the power is turned on.
- Press the “4” key on the keypad with the shift key held down to select the block mode.
- Every time the “4” key on the keypad is pressed, the mode display is switched.

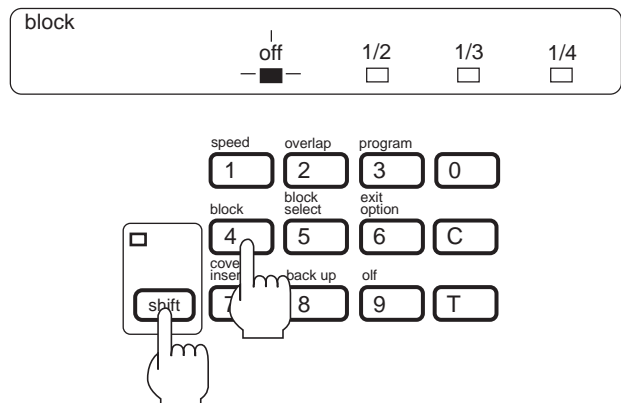

## 18 Select the cover insert mode.

- The cover insert mode is set to “off” when the power is turned on. Start operation to perform normal collation operation.
- Set the cover insert mode as required to perform collation with cover inserted.
- Press the “7” key on the keypad with the shift key held down to select the mode.
- Every time the “7” key on the keypad is pressed, the mode display is switched.

For further details, refer to “9. USING THE COVER INSERT MODE”.

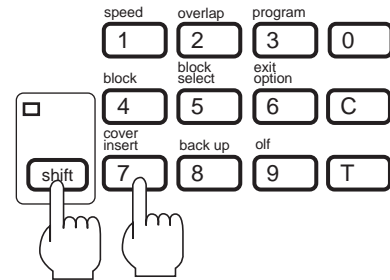

## 19 Select the double-feed sensitivity switch.

- Set the switch up when paper thickness is 157 g/m<sup>2</sup> or less. Set the switch down when paper thickness is 157 g/m<sup>2</sup> or more.
- Set the switch to “off” to cut the double-feed detection function when the following paper is mis-detected.
  - ① folded paper
  - ② colored paper
  - ③ paper printed within a margin of 10 mm from the detective section.

**NOTE**: The machine does not stop when a double feed occurs with the switch off.

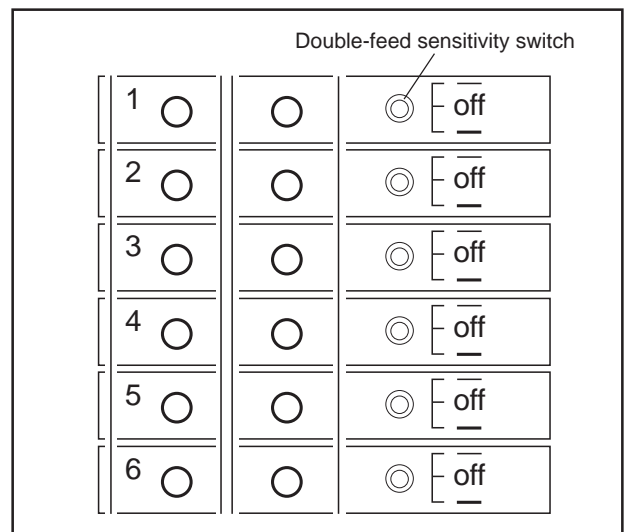

## 20 Press the reset key.

- One set of sheets of paper is ejected. Check whether the set is normally collated.

Select the ejection direction with the DIP switch: to the reject tray or to the downstream processing machine.

For further details, refer to “4. FUNCTION OF THE DIP SWITCHES AND THEIR USE”.

- Check and adjust the following sections when a double-feed or mis-feed occurs.

- ① Paper guide section
- ② Pad height
- ③ Bin pressure
- ④ Shutter section
- ⑤ Switch the double-feed detective sensitivity.
  - \* Some types of paper are not applicable to the standards described in the item (19). Set the sensitivity switch to the suitable setting according to paper type.

The reset key can be used when the set qty display is “0”.

Note that the reset key cannot be used when “0” is not displayed.

When the double-feed error is displayed while resetting, it indicates that the data of the paper of that bin could not be read properly. Check the double-feed detection sensitivity SW and reset again.

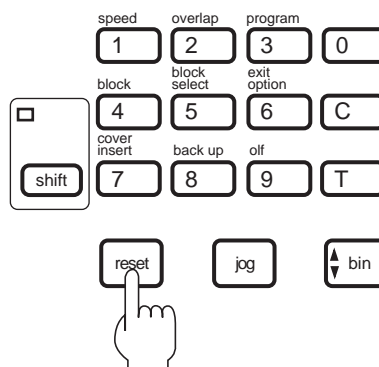
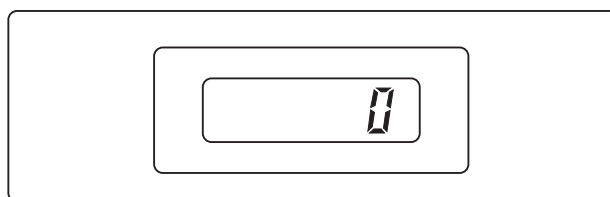

## 21 Input the number to be processed.

- Input the number to be processed on the keypad.

The number to be processed input will only be valid for tower A.

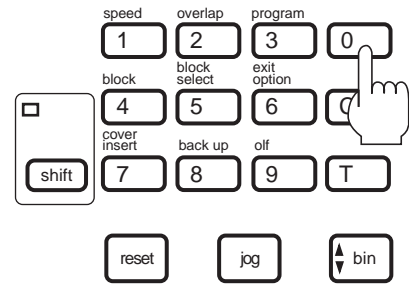
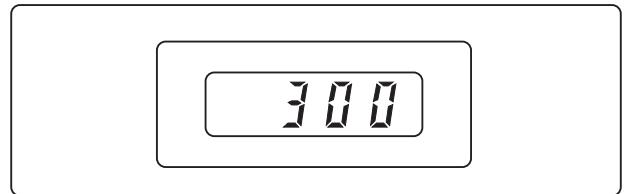

## 22 Press the start key to commence operation.

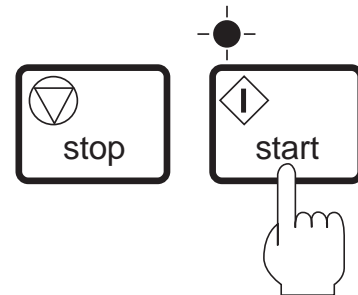

Turn the power on Tower A off first.

## 12. FEEDING SMALL PAPER (ONLY WHEN DBM-200 IS CONNECTED)

When feeding paper less than 200 mm wide, change the air feeding position with the separator shutter as shown in the figure.

**NOTE** : Paper less than 200 mm wide can be fed only when DBM-200 is connected. In this case, use the corner guide provided with DBM-200.

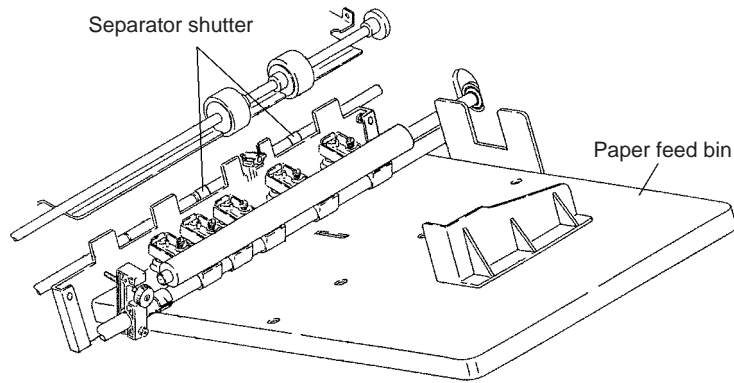

### <Normal use>

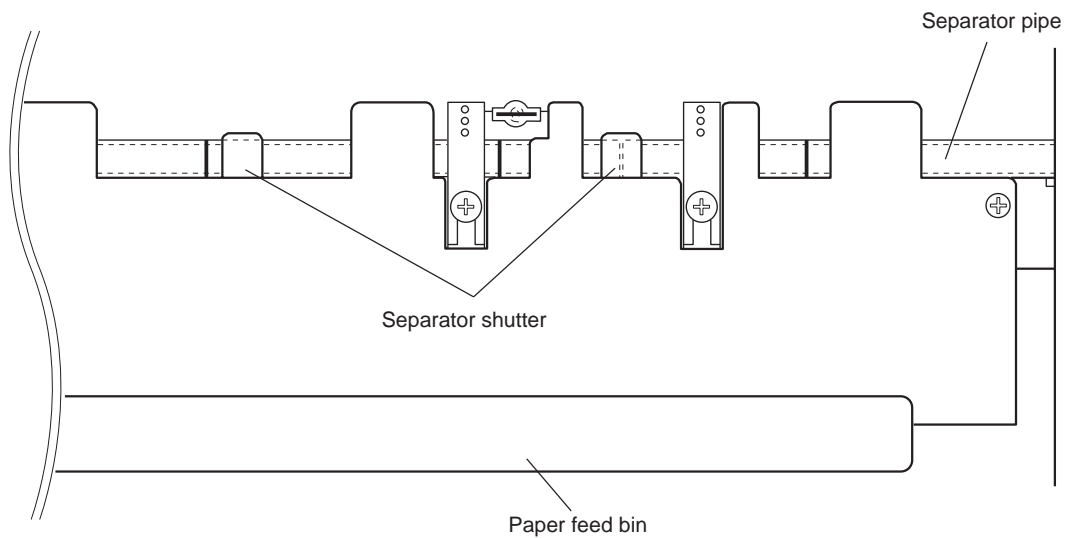

### <For small paper>

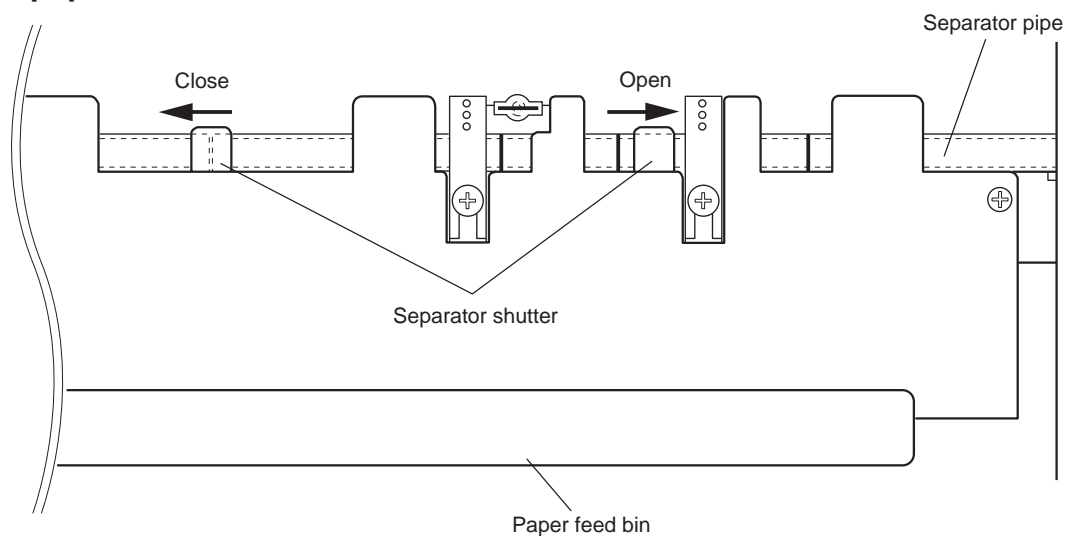

# 13. USING THE LU-HM

The LU-HM feeds paper automatically when inserting several sheets (below 10) of paper manually.

## 13-1. Manual Mode 1

**1** Push 3 and 4 of DIP SW2 of tower A down (numerals).

This mode can be used only for the “Auto” mode and when the block mode is off.

\* When set to the manual mode, the first digit “d.p” will blink.

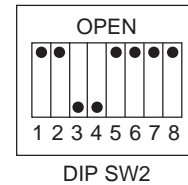

**2** Adjust the HM section paper guide to the size of the paper.

**3** Insert the auxiliary table into the square holes according to the size of the paper as shown in the figure.

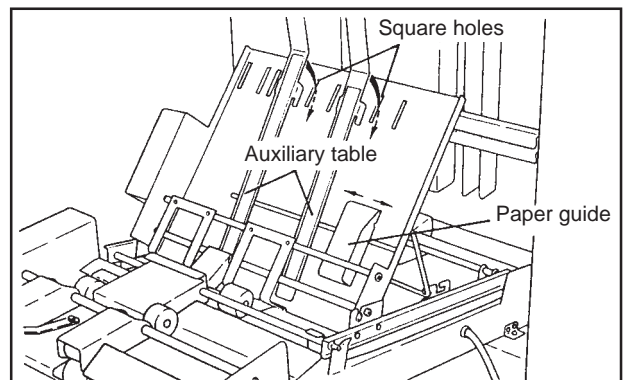

**4** Press the start key of the tower to start the machine.

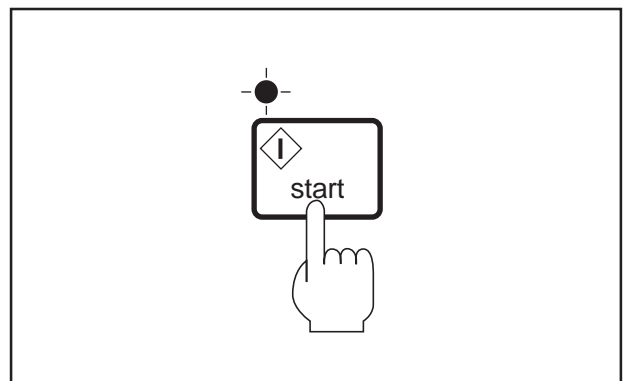

- Set collated sets (less than 10 sheets) in the HM section.

The tower will standby to feed paper until paper is set in the HM section.

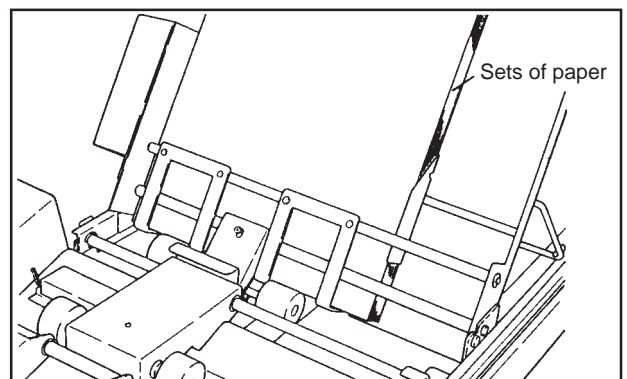



**5** Paper will be fed from the tower when the paper switch of the HM section is pressed.

- The claws of the HM section will open, and sets of paper from the HM section and the sets of paper from the tower will be combined in the conveyance route.

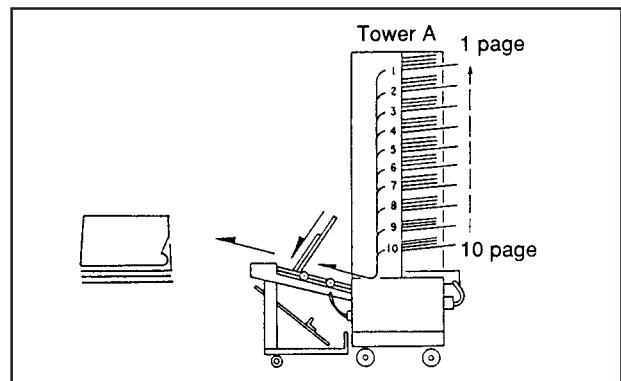
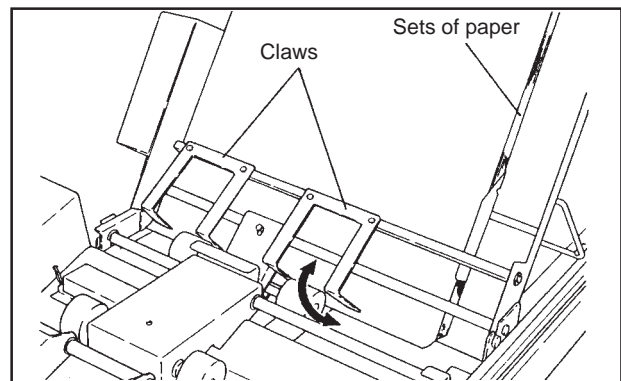

## 13-2. Manual Mode 2

This mode allows sets of paper to be set in the HM section according to the paper feeding operation. Therefore, its efficiency is higher than mode 1 as more sets of paper can be processed.

- 1 Push 3 of DIP SW2 of tower A down (numerals).

\* When set to the manual mode, the first digit “d.p” will blink.

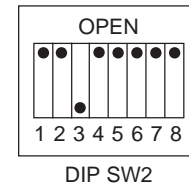

- 2 Adjust the HM section paper guide to the size of the paper.
- 3 Insert the auxiliary table into the square holes according to the size of the paper as shown in the figure.

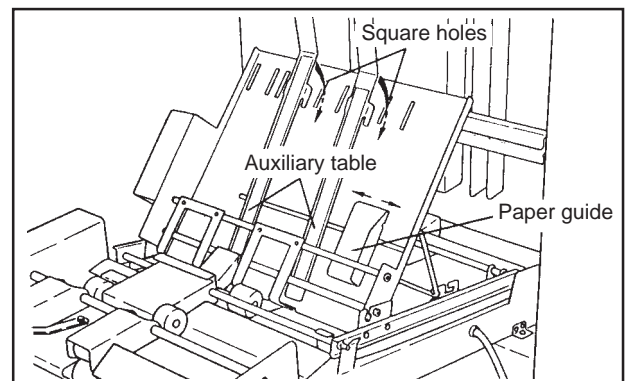

- 4 Press the start key of the tower to start the machine.

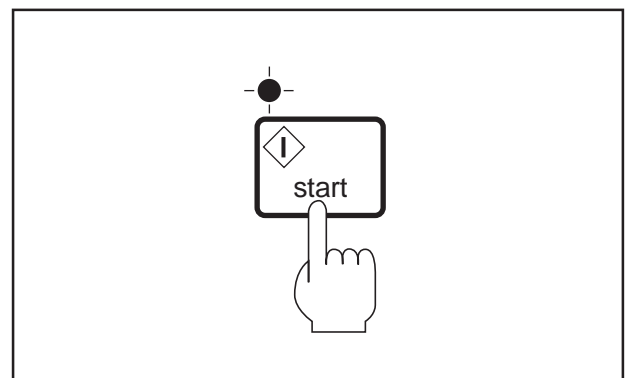

- Set paper in the HM section according to the paper feeding operation of the tower.

The tower will start feeding paper regardless of whether there are sets of paper in the HM section or not.

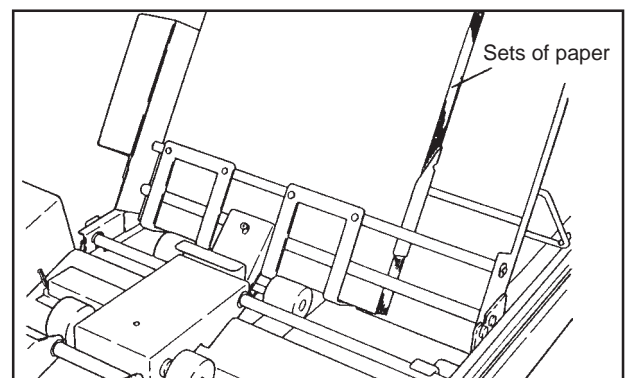

# 14. SUPPLEMENTARY OPERATION TO BE PERFORMED WHEN THE MACHINE IS IN OPERATION

## 14-1. Checking the Accumulated Total Number of Sets Collated

Press the T key to check the accumulated total number “300” of sets collated.

The accumulated total number of sets is displayed on the display window while the T key is pressed.

Once the power is turned off, the number becomes 0.

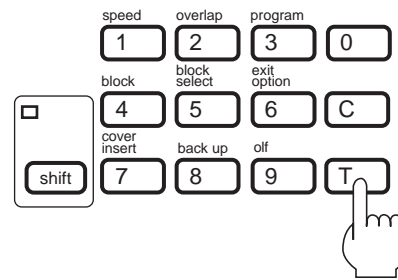
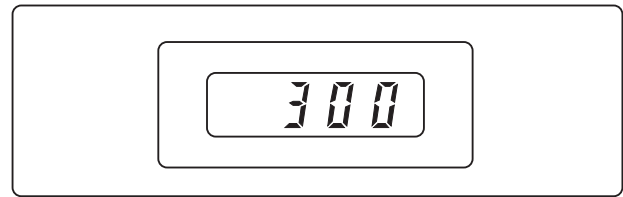

## 14-2. Checking the Number of Sets Rejected

Check the number of sets rejected to the reject tray as follows.

- Press the T key with the shift key held down. The number of sets rejected is displayed on the display window while the T key is pressed. The display in the figure on the right indicates that 12 sets have been rejected.

The counter can be cleared using “Shift” + “T” + “C” (approx. 1 second).

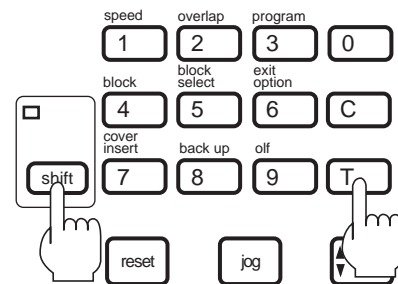
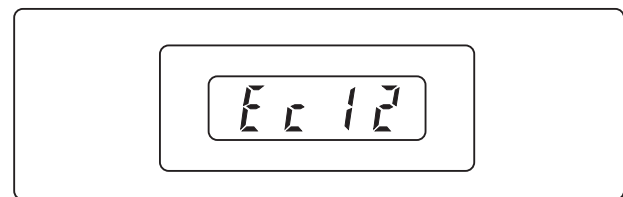

## 14-3. Decreasing Processing Speed

- Press the “1” key on the keypad with the shift key held down. Every time the “1” key on the keypad is pressed, the display moves in the direction of (-) and processing speed of the machine is decreased.

Depending on type of the downstream processing machine, the paper conveyance interval may be widened.

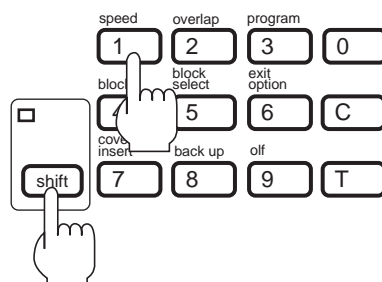

**NOTE** : Stop operation to decrease processing speed.

## 14-4. Changing the Overlap Volume in Conveying Paper

Change the overlap volume in conveying paper so that the ejected paper is in alignment, when the ejected paper is not in alignment.

Take the following procedures to change the overlap volume.

- Press the “2” key on the keypad with the shift key held down.

Every time the “2” key on the keypad is pressed, the display moves in the direction of (+) and paper conveyance intervals is widened.

**NOTE** : Stop operation to switch the intervals.

- Overlap amount and conveyance intervals are listed below:

**NOTE** : The following overlap amounts will differ according to the downstream processing machine connected.

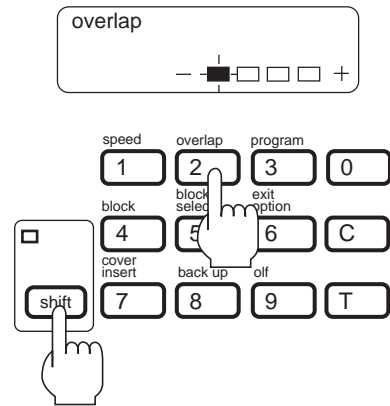
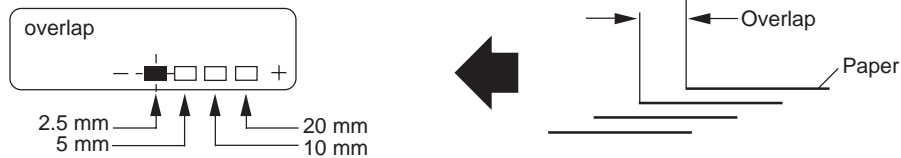

## 14-5. Returning to the Previous Mode by Turning Power ON Again after Power is Cut OFF during Operation

When the power is cut off during operation, take the following procedures to return the display on the control panel to the previous mode:

- Press the “8” key on the keypad with the shift key held down.

When the “8” key is pressed continuously for approximately 1 second, the display shows the previous mode before the power is cut off.

The accumulated number of sets collated is also restored.

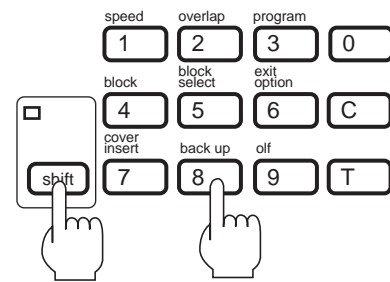

## 14-6. Operating the Stitcher Manually

When the stitcher (DC-48SH 3) is connected, take the following procedures to perform manual stitching operation.

- Press the “9” key on the keypad with the shift key held down.

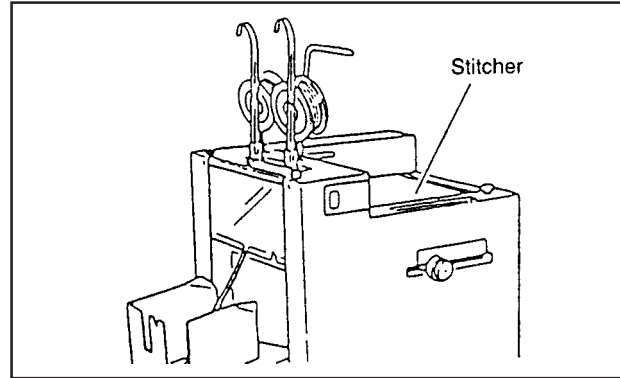
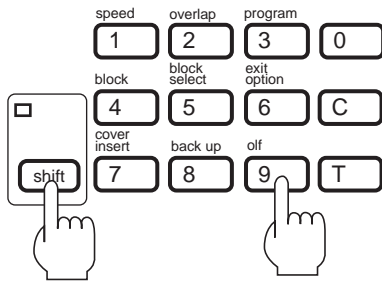

- When the “9” key on the keypad is pressed, the stitcher works so that manual stitching can be performed.

Press the “9” key on the keypad with the shift key held down to stop manual stitching.

- Raise the sensor unit and conveyance weight as shown in the figure.

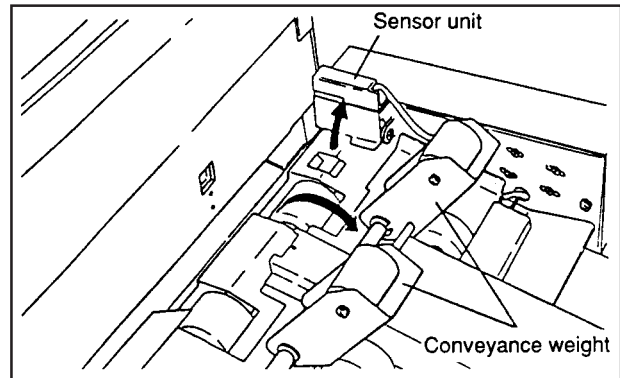

- When the paper is inserted into the conveyance entrance of the stitcher and conveyed through the unit, the paper is automatically stitched.

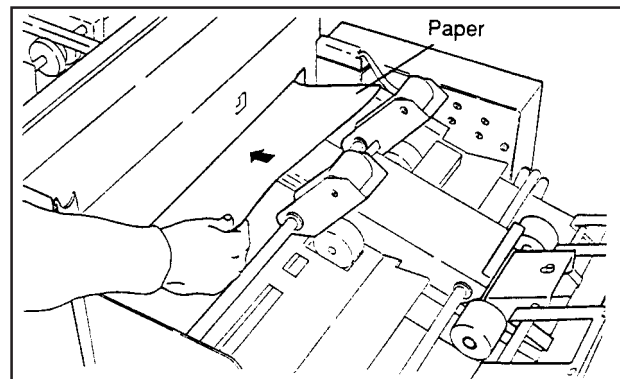

# 15. CLEARING PAPER JAMS

## 15-1. Jamming in the Feeding Section

- 1 Press the paper feed bin key to lower the paper feed bin.

**NOTE** : Do not press down the bin manually.

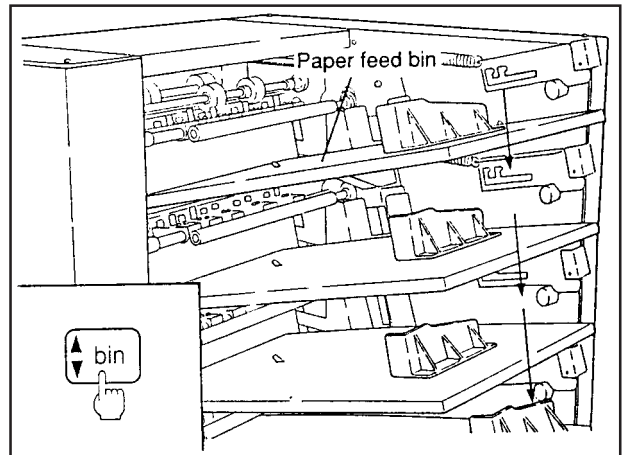

- 2 Remove the jammed paper toward you. Be careful not to remove the pad.

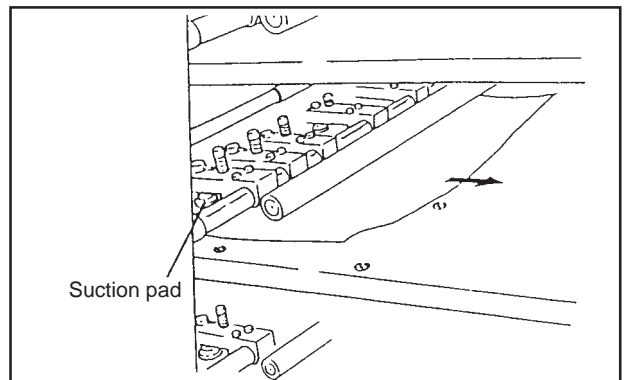

- 3 Press the jog key to eject paper shreds if there are.

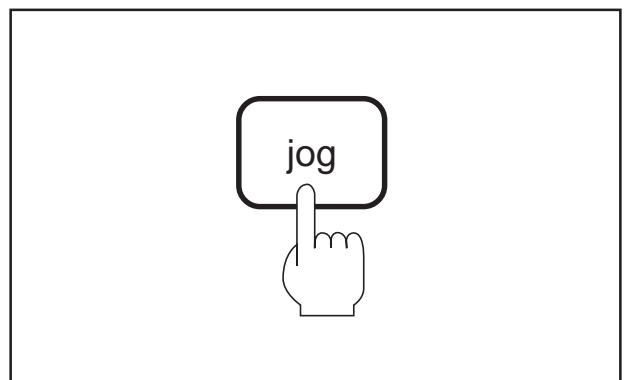

## 15-2. Jamming in the Vertical Conveyance Section

- 1 Press the jog key to eject the jammed paper.

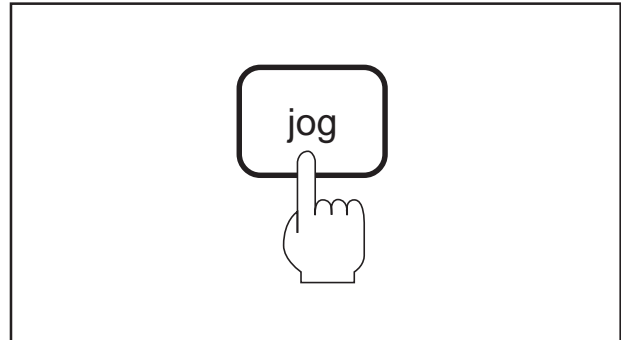

- 2 If the jammed paper is not removed with the jog key, open the vertical conveyance board toward you to remove the jammed paper.

- Close the vertical conveyance board firmly when the jammed paper is removed.

**NOTE** : The machine does not restart operation if the board is not firmly closed.

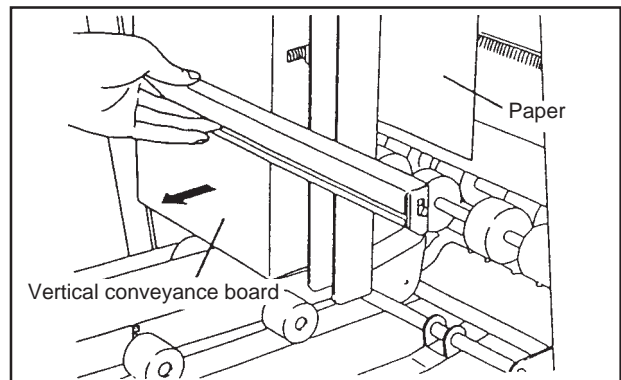

## 15-3. Jamming in the Lifting Unit Section

- 1 Press the jog key to eject the jammed paper.

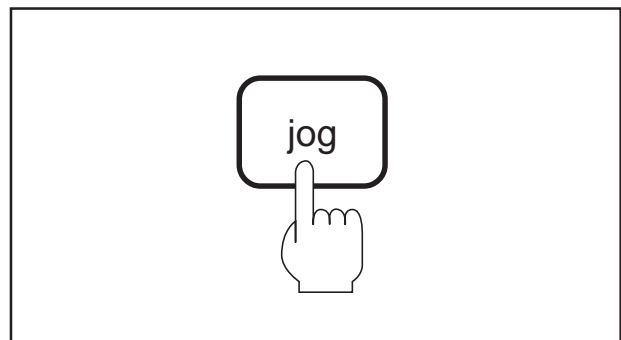

- 2 When the jammed paper is not ejected with the jog key, open the conveyance board to remove it.

**NOTE** : The machine does not restart operation if the board is not firmly closed.

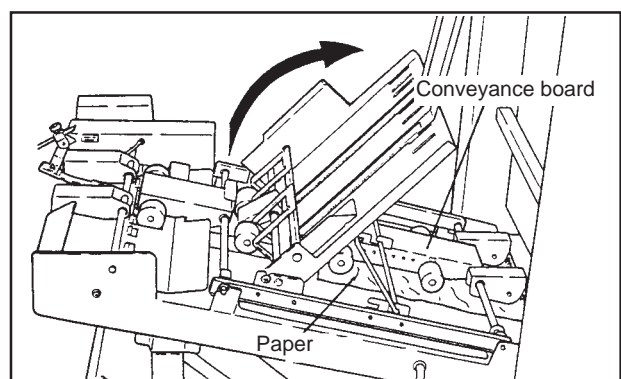

## 15-4. Jamming in the Conveyance Bridge Section

- 1 Press the jog key to eject the jammed paper.

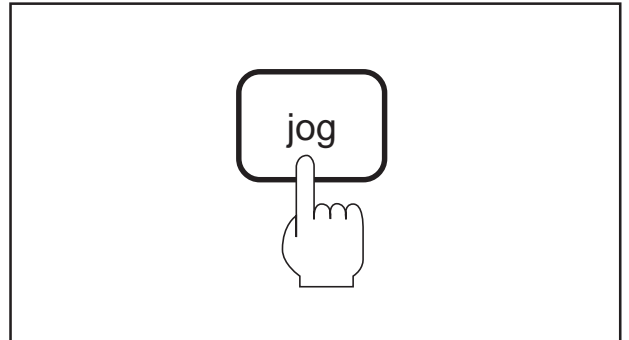

- 2 When the jammed paper is not ejected with the jog key, open the conveyance board to remove it.

- Close the board firmly after the jammed paper is removed.

**NOTE** : The machine does not restart operation if the board is not firmly closed.

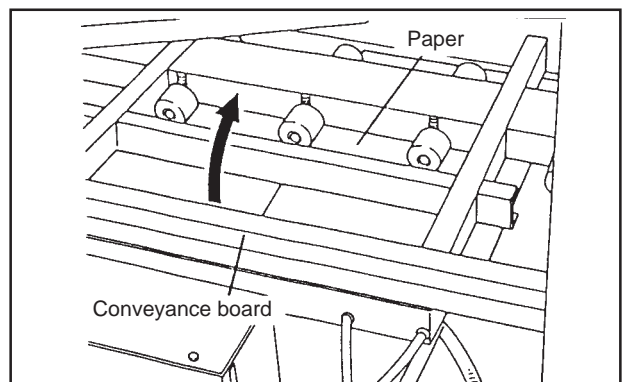

## 15-5. Jamming in the Right Ejection Unit Section

- 1 Press the jog key to eject the jammed paper.

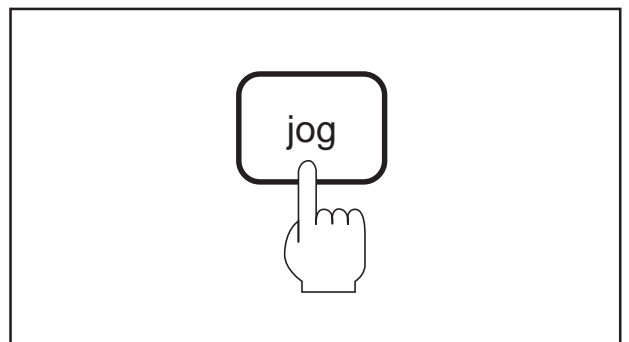

- 2 When the jammed paper is not ejected with the jog key, open the conveyance board to remove it.

- Close the conveyance board firmly after the jammed paper is removed.

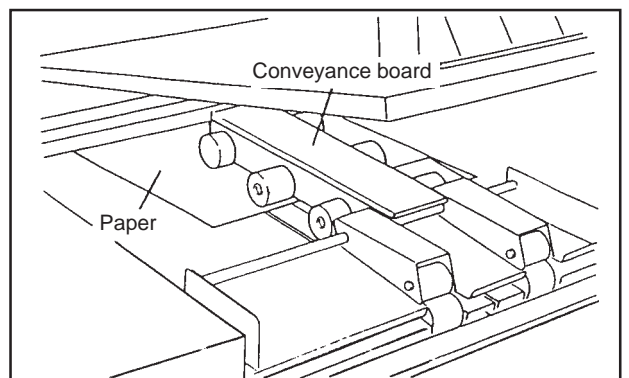



# 16. REPLACING THE SUCTION PAD

- The suction pad is inserted into the valve shaft end. Pull the suction pad to remove.

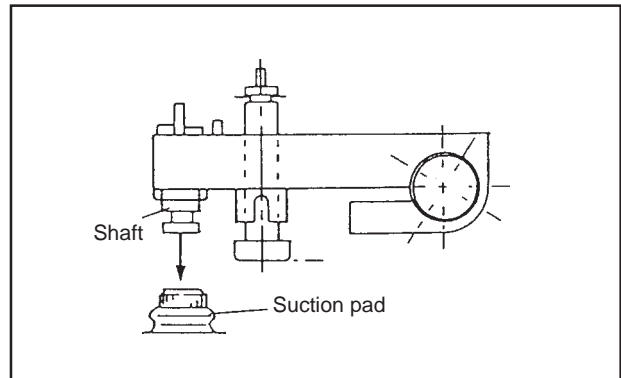

- Insert a new suction pad into the valve as shown in the figure.

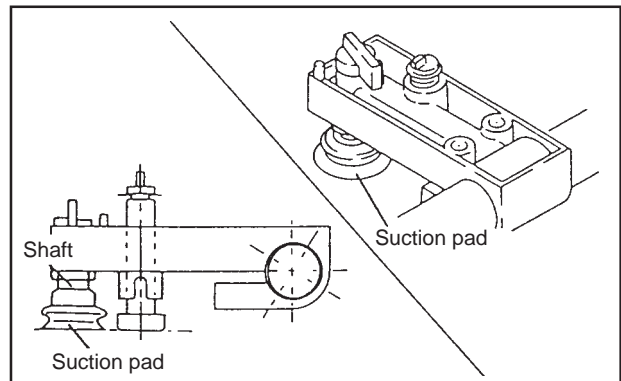

**NOTE** : After it is replaced, make sure that the suction pad does not slant. If it does, straighten it.

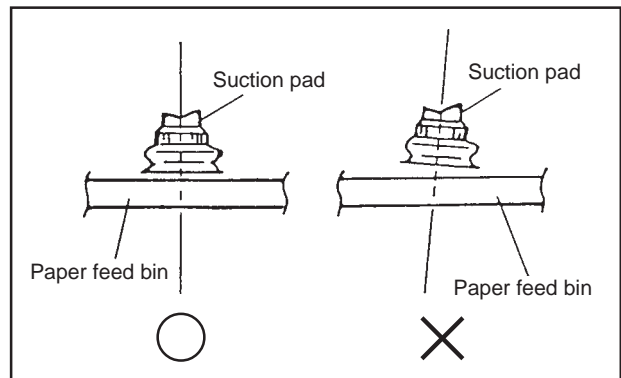

# 17. MONITOR LAMP DISPLAYS AND THEIR COUNTERMEASURES

Monitor lamps are built into the control panel to display where problem arises.

Take the following procedures when the monitor lamp lights up.

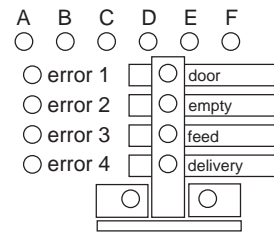

## 17-1. When the door Lamp Lights Up

The DOOR lamp lights up when the conveyance board on the vertical conveyance section, conveyance bride section or lifting unit section is not firmly closed.

- ① Check whether the vertical conveyance board is firmly closed on the tower where the lamp is lit.

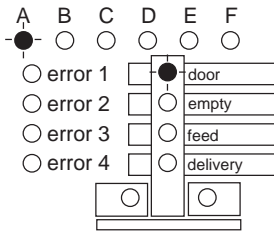

- Close it firmly if it is not.

The machine restarts operation when the lamp disappears.

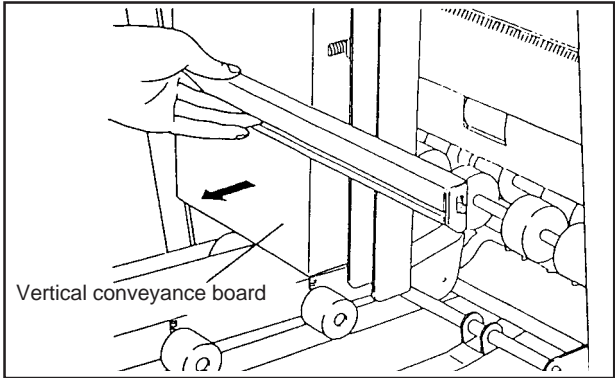

- ② Check whether the conveyance board on the conveyance bridge (right) is firmly closed on the tower where the lamp is lit.

- Close the conveyance board firmly if it is not.

The machine restarts operation when the lamp disappears.

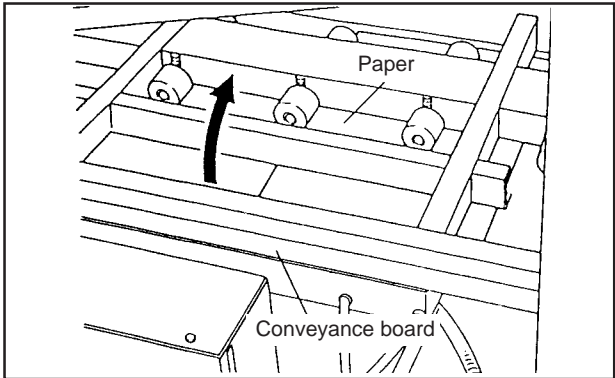

③ Check whether the conveyance board on the lifting unit section is firmly closed.

- Close it firmly if it is not.

The machine restarts operation when the lamp disappears.

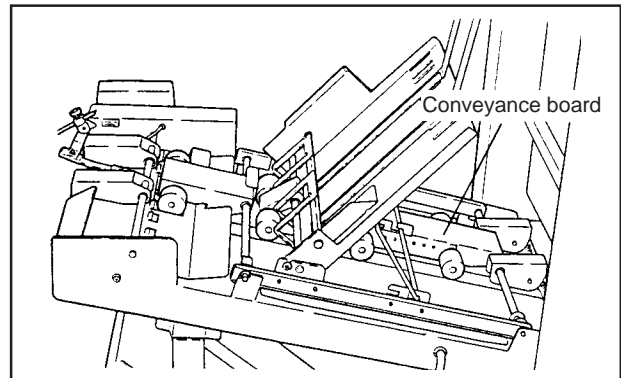

## 17-2. When the empty Lamp Lights Up

The EMPTY lamp lights up when the paper runs out on the paper feed bin. At the same time, the paper lamp on the relevant tower flashes on and off.

① Check the paper feed bin No. where the paper lamp flashes on and off.

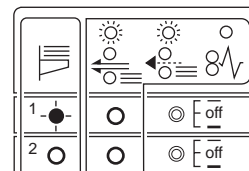
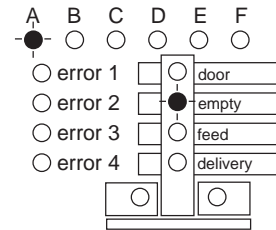

② Load paper.

- If the START key is pressed without replacing the paper, the buzzer will sound to alert you of this.

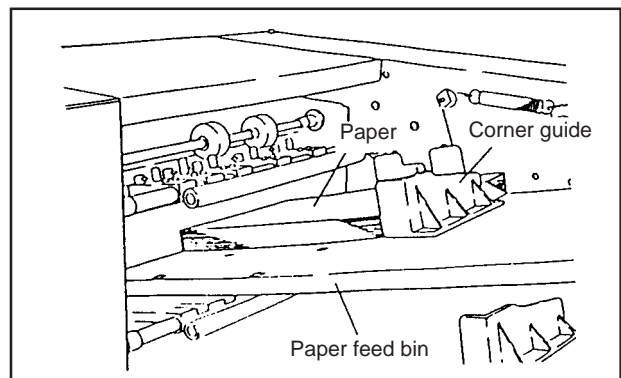

③ Check whether the error 1 or 2 lamp lights up or not.

- Restart operation when any of the lamps is not lit.

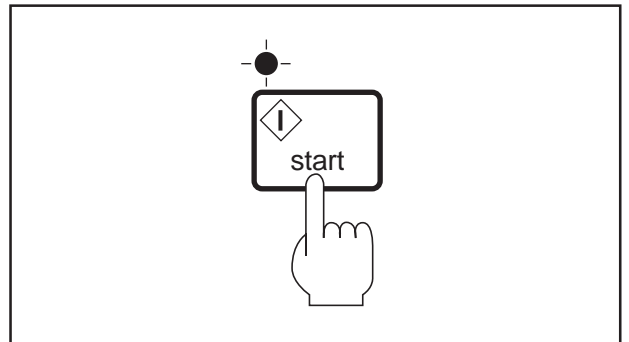

④ When the error lamp 1 is lit with the paper ejection direction mode set to the left:

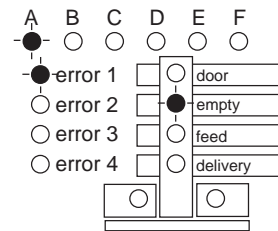

- Check the set ejected to the reject tray as it is mis-collated.

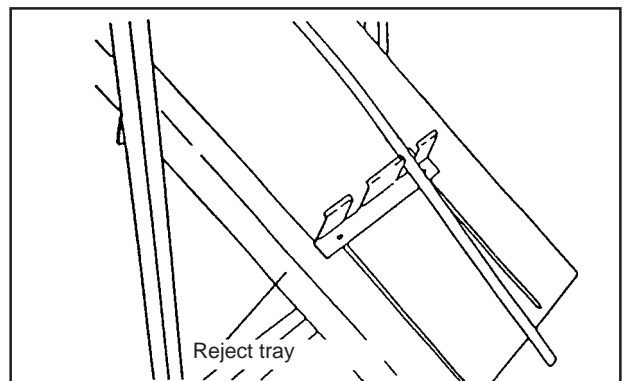

- When the error 2 lamp is lit, check the set ejected to the downstream processing machine and all the sets ejected to the reject tray.

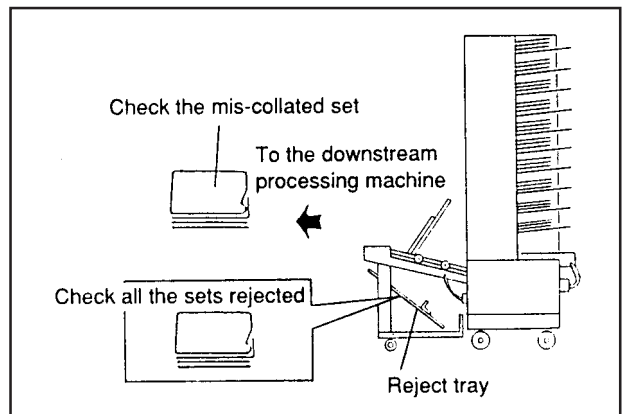
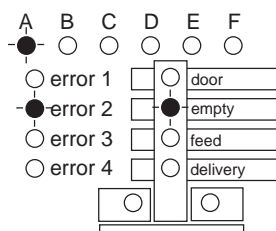

- ⑤ When the error 1 lamp is lit with the paper ejection direction mode set to the right:

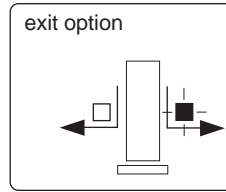

- Check the set ejected last to the downstream processing machine as it is mis-collated.

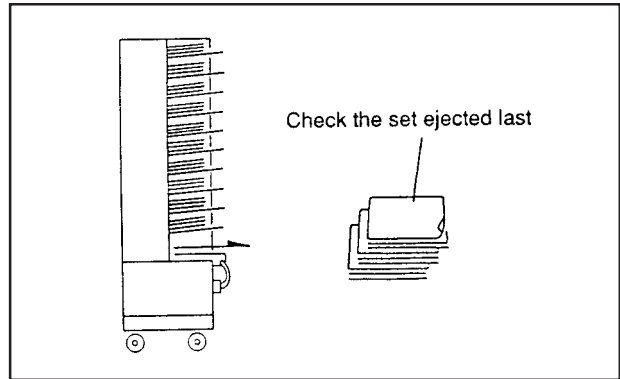
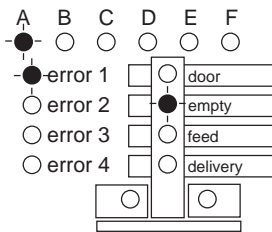

- When the error 2 lamp is lit, check the last two sets ejected to the downstream processing machine as they are mis-collated.  
(But the last set may not contain the error.)

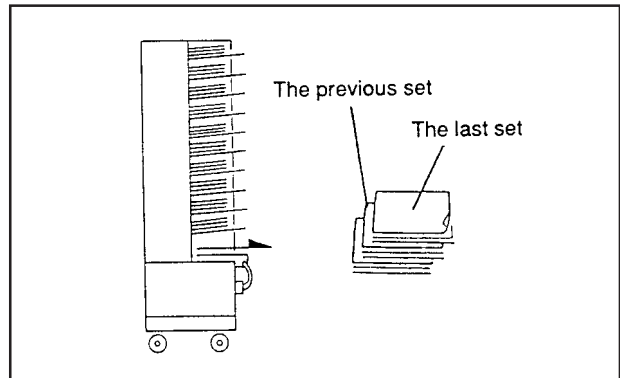
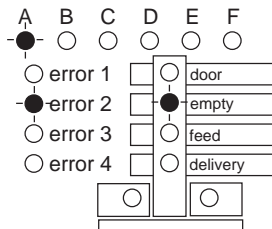

## 17-3. When the feed error Lamp Lights Up

The FEED ERROR lamp lights up when a double-feed, mis-feed or paper jam occurs. Furthermore, the double-feed, mis-feed, paper jam display lamp lights up according to error type. These display lamps are on each paper feed bin.

- ① When the double-feed display lamp blinks, check the ejected sets as the sheets of paper on the bin where the lamp blinks have been double-fed.

**NOTE** : Note that “double-feed” may be mis-detected, when a different type of paper is fed or when the paper is fed askew.

- Check the ejected sets according to the state of the lit lamp.

Refer to “17-2. When the empty Lamp Lights Up”.

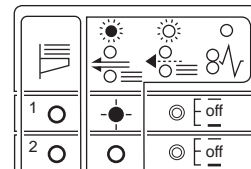
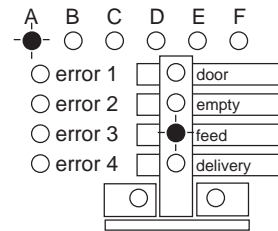

- ② When the mis-feed display lamp blinks, check the ejected sets as the paper on the bin where the lamp blinks have not been fed.

- Check the ejected sets according to the state of the lit lamp.

Refer to “17-2. When the empty Lamp Lights Up”.

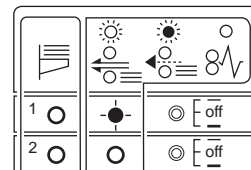
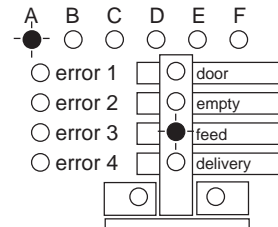

- ③ When the paper jam display lamp lights up, remove the jammed paper as a paper jam occurs on the bin where the lamp lights up.

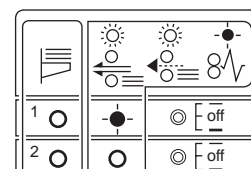
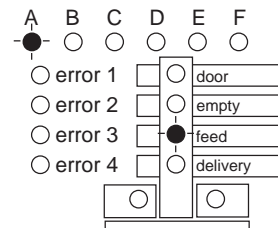

## 17. MONITOR LAMP DISPLAYS AND THEIR COUNTERMEASURES

---

- Check whether the ejected sets are well collated.
- Check the ejected sets according to the state of the lit lamp.

Refer to “17-2. When the empty Lamp Lights Up”.

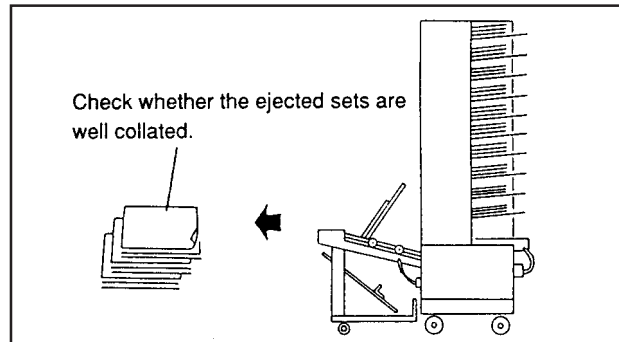

## 17-4. When the delivery Lamp Lights Up

- ① Remove the jammed paper as a paper jam occurs on the conveyance bridge on the left side of the relevant tower.

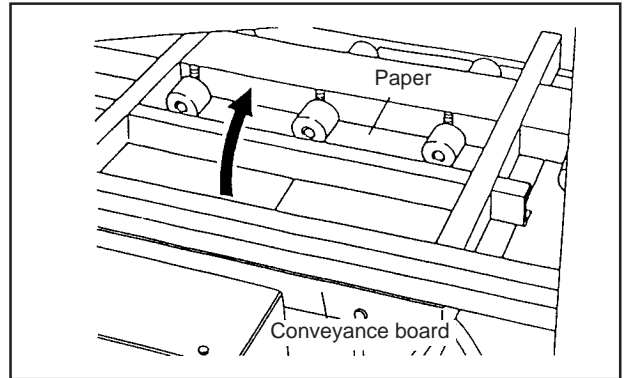
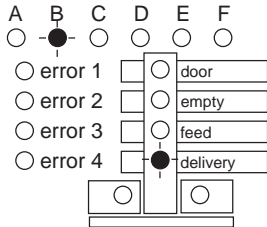

- Check whether the ejected sets are well collated.
- Check the ejected sets according to the state of the lit lamp.

Refer to “17-2. When the empty Lamp Lights Up”.

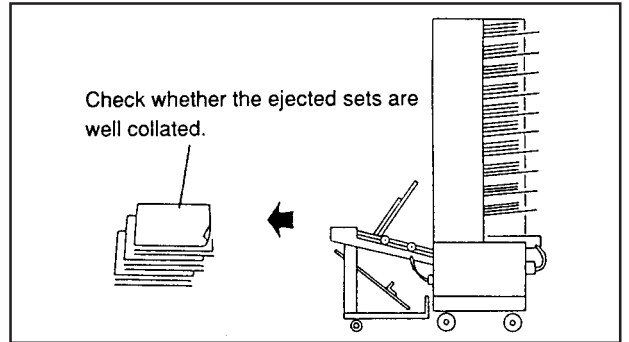

- ② Release the error as error occurs in the downstream processing machine on the left when the left exit option lamp lights up.

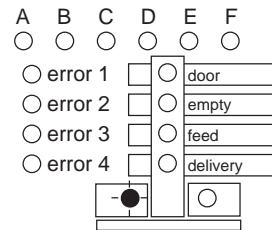

- ③ Release the error as error occurs in the downstream processing machine on the right when the right exit option lamp lights up.

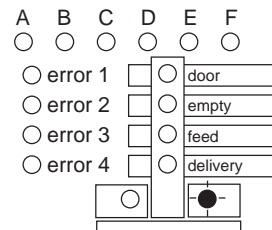



# 18. TROUBLESHOOTING GUIDE

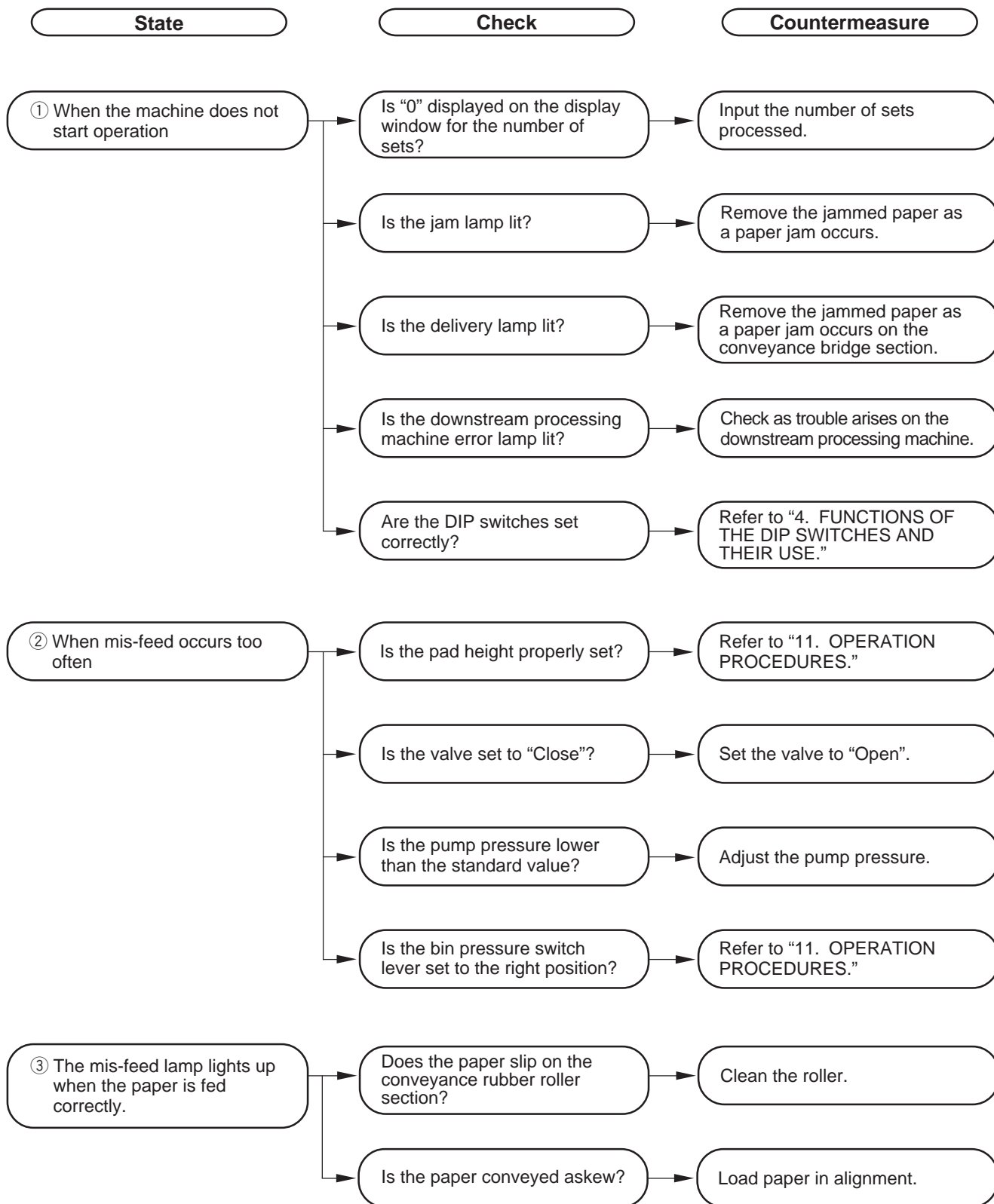

State	Check	Countermeasure
④ When a double feed occurs	Is the paper guide attached correctly?	Refer to "11. OPERATION PROCEDURES."
	Is the shutter set correctly?	Refer to "11. OPERATION PROCEDURES."
⑤ Paper is fed normally but the double-feed lamp lights up	Is the reset operation performed in advance?	Perform the reset operation when the paper is replaced.
	Is the double-feed detection sensitivity switch set properly?	Refer to "11. OPERATION PROCEDURES."
	Has paper been conveyed slanted?	Load the paper neatly.
	Set the double-feed detection sensitivity switch to "Off".	
⑥ When "E-□-□" are displayed	Contact the dealer in your area.	

# 19. EVERYDAY CLEANING

When the conveyance rubber roller, conveyance roller and conveyance belt become dirty with ink or paper shreds, they may cause mechanical trouble or malfunction. Clean the machine once a month.

Clean the machine with a soft cloth wet with water or synthetic detergent.

① Cleaning the conveyance rubber roller

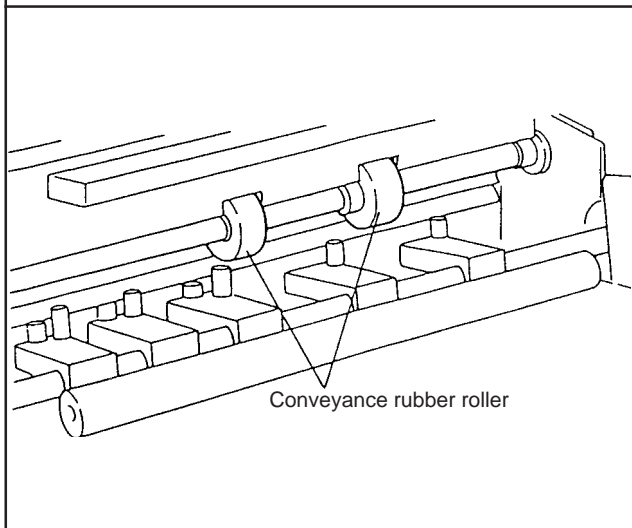

② Cleaning the conveyance roller

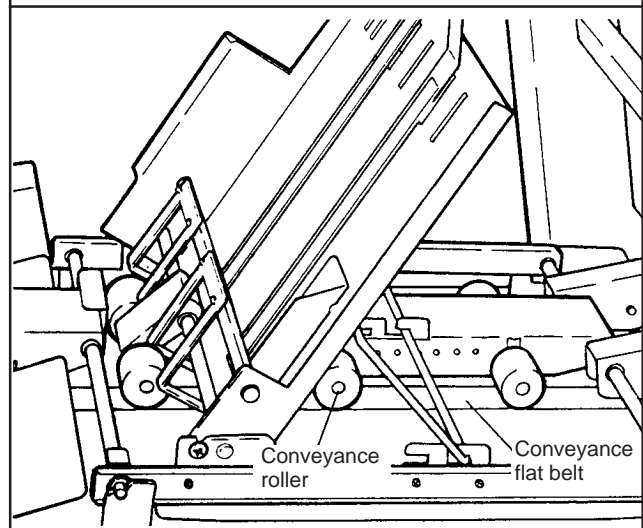

③ Cleaning the vertical conveyance rubber roller

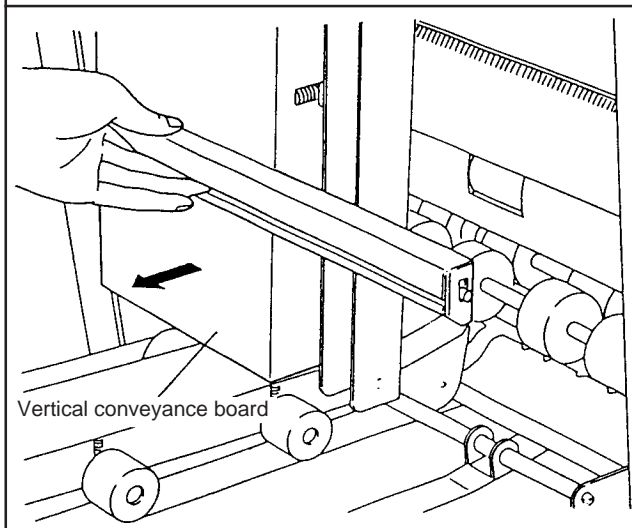

④ Cleaning the conveyance flat belt

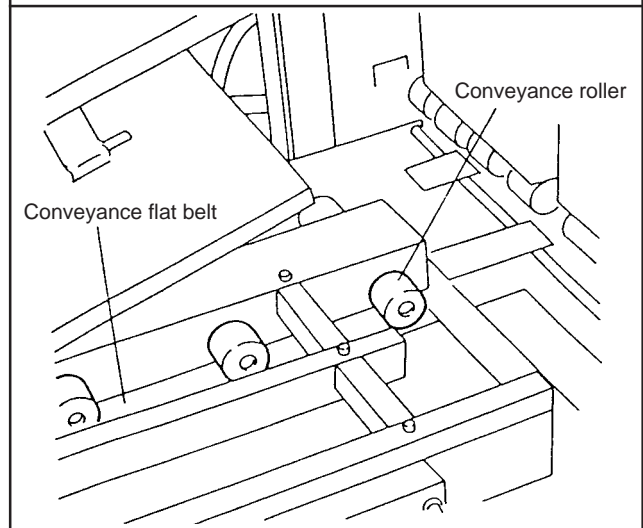

## 20. CHECKING AND MAINTENANCE OF THE DRY PUMP

---

**1** The gauge pressure of the dry pump is set in advance as follows:

Exhaust pressure: 0.5 kgf/cm<sup>2</sup>

Suction pressure : 20 cm Hg

**NOTE** : Do not operate the machine in the higher pressure than the above as that is dangerous.

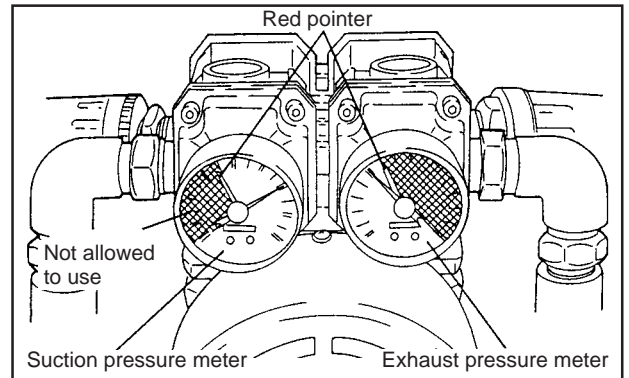

**2** When the dry pump filter is clogged, the gauge pressure does not change but feeding performance may be deteriorated.  
Contact the dealer in your area.

# 21. SPECIFICATIONS

Model		DC-10000S
Type		Floor type
The number of sheets to be collated		10 sheets/tower
The number of towers to be connected		Six towers (max. 60 bins)
Feeding method		Air suction method Paper separator brush, air blowing method
Conveyance system		Twin roller belt system
Bin capacity Max.		55 mm (Maximum bin capacity is 40 mm in case of less than 200 mm feeding width)
Paper size	Min. Max. Feeding width Feeding length	140 × 200 mm 350 × 500 mm 200 to 350 mm 140 to 500 mm (Minimum feeding width is 120 mm, only when connected DBM-200)
Paper quality		Fine quality paper Bins Nos. 1 to 2, 9 to 10 52.3 to 250 g/m <sup>2</sup> 3 to 8 52.3 to 157 g/m <sup>2</sup> Stencil fine quality paper, medium quality paper Art/coated paper 79.1 to 157 g/m <sup>2</sup>
Paper style		Sheet Single-folded paper (less than 80 g/m <sup>2</sup> , 8 bins or less) Double-folded paper (less than 80 g/m <sup>2</sup> , 4 bins or less)
Processing speed		Max. 3000 sets/hour (when L jogger (left ejection) connected, 10 sheets/tower used) Max. 4700 sets/hour (when 5 bins in two or more connected towers are used in the program mode with the jogger connected) R jogger (right ejection): max. 1980 sets/hour (when 10 bins used )
Mis-feed detection		Double-feed detection (2 settings or off) mis-feed detection paper jam detection
Other detection functions		No paper detection, conveyance way paper jam detection, conveyance way door open/close detection
Error display		Displayed on the control panel Each tower door close/open, empty, feed error, conveyance error, downstream processing machine error, empty bin, double-feed, mis-feed, paper jam
Counter		Input on the keypad, 5-figure subtraction counter (repeat motion)
Additional functions		Cover insert mode Program functions (5-bin cluster mode, 10-bin cluster mode) Alternate all mode (2 bins to 1 bin) Block functions (1/2, 1/3, 1/4) Changing processing speed : 4 settings Processing speed change according to downstream processing machine conditions Paper intervals : 4 settings Intervals change according to downstream processing machine conditions Counter back up function Paper thickness memorizing function: normal paper, thick paper detection off, switching function Double-feed non-detection on each bin Non-multi-feed function Double-feed, mis-feed paper jam non-detection function Start/stop switch Jog switch, feed bin up/down switch Ejection direction selection switch (left ejection: only Tower A) Manual ON/OFF (only when DC-48SH 3 is connected) Air blowing ON/OFF Reject function

Model		DC-10000S			
Dimensions	Main body	760 (W) × 700 (d) × 2045 (h) mm			
	2-connected	1640 (W) × 700 (d) × 2045 (h) mm			
	3-connected	2520 (W) × 700 (d) × 2045 (h) mm			
	4-connected	3400 (W) × 700 (d) × 2045 (h) mm			
	5-connected	4150 (W) × 700 (d) × 2045 (h) mm			
	6-connected	5030 (W) × 700 (d) × 2045 (h) mm			
Mass (Weight)	Main body	280 kg			
Power Consumption	Main body	230 to 240 V $^{+6\%}_{-10\%}$ 50 Hz			
Acoustic Noise	Main body (4) LU-HM DC-8000S P (2) DC-48SH 3	The measurement method - Based upon EN 27779			
		Front	Back	Left	Right
		77.2 dB (A)	76.0 dB (A)	74.8 dB (A)	76.5 dB (A)
Acoustic Noise	Main body (3) LU-HM DC-8000S P (2) DC-48SH 3 DC-48F 3 DC-48T 3	The measurement method - Based upon EN 27779			
		Front	Back	Left	Right
		77.7 dB (A)	77.2 dB (A)	76.0 dB (A)	75.2 dB (A)

\* Main body (4) means when four units are connected, Main body (3) means when three units are connected.  
DC-8000S P (2) means two of use.

Specifications and dimensions are subject to change without prior notice for improvements.

